

# **FX60/FXT60**

**Tier 4**

## **Operator's Manual**



**CE**

**CMW<sup>®</sup>**

**Issue 2.0**

**053-2754**

# Overview



## Chapter Contents

<b>Serial Number Location</b> .....	<b>2</b>
<b>Intended Use</b> .....	<b>2</b>
<b>Equipment Modification</b> .....	<b>3</b>
<b>FX60 Unit Components</b> .....	<b>3</b>
• 800 gallon tank .....	.3
• 1200 gallon tank .....	.4
<b>FXT60 Unit Components</b> .....	<b>5</b>
• 500 gallon tank .....	.5
• 800 gallon tank .....	.6
<b>FCC Statement</b> .....	<b>7</b>
<b>Operator Orientation</b> .....	<b>8</b>
<b>About This Manual</b> .....	<b>8</b>
• Bulleted Lists .....	.8
• Numbered Lists .....	.8

## Serial Number Location

Record serial numbers and date of purchase in spaces provided. FX60 serial number is located as shown.

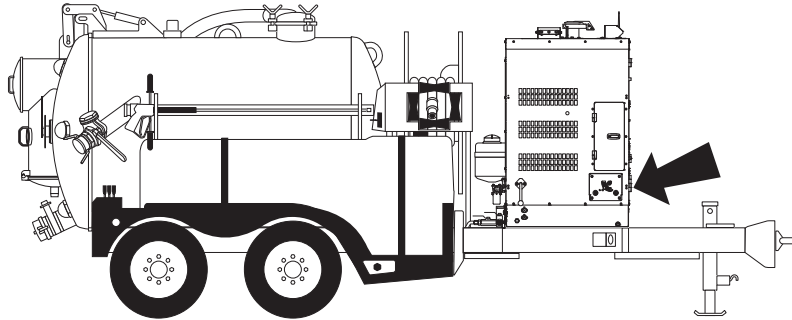

j430m001h.eps

Date of manufacture	
Date of purchase	
FX60 serial number (shown)	
Engine serial number	
Blower serial number	
Water pump serial number	
Trailer serial number	

## Intended Use

The FX60 is a self-contained vacuum excavation unit capable of vacuuming a wide variety of non-hazardous, non-flammable liquid and solid debris. The FXT60 is a truck-mounted version of the FX60 vacuum excavation unit. They are designed to perform efficient soft excavation, including exposing utilities for visual verification and/or potholing. The optional reverse flow system allows for spoils transfer to another tank. The FX60 and FXT60 are intended for operation in ambient temperatures from 0° to 115°F (-18° to 46°C). Use in any other way is considered contrary to the intended use.

The FX60 and FXT60 should be operated, serviced, and repaired only by persons familiar with its particular characteristics and acquainted with the relevant safety procedures.

## Equipment Modification



This equipment was designed and built in accordance with applicable standards and regulations. Modification of equipment could mean that it will no longer meet regulations and may not function properly or in accordance with the operating instructions. Modification of equipment should only be made by competent personnel possessing knowledge of applicable standards, regulations, equipment design functionality/requirements and any required specialized testing.

## FX60 Unit Components

### 800-Gal (3028-L) Tank

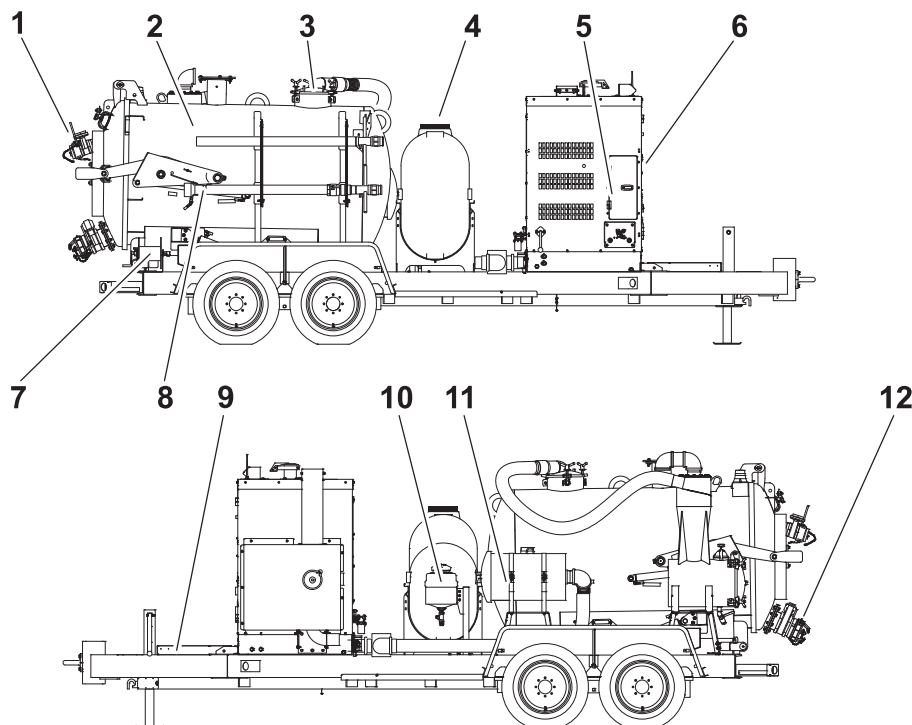

j43om002h.eps

- |                          |   |
|--------------------------|---|
| 1. Inlet valve           | 7. Hose reel - wash pump                  |
| 2. Vacuum tank           | 8. Potholing tools                        |
| 3. Primary shutoff valve | 9. Tool storage                           |
| 4. Water tank            | 10. Antifreeze tank                       |
| 5. Operator's station    | 11. Vacuum filter/secondary shutoff valve |
| 6. Power pack            | 12. Drain/Outlet valve                    |

**1200-Gal (4542-L) Tank**

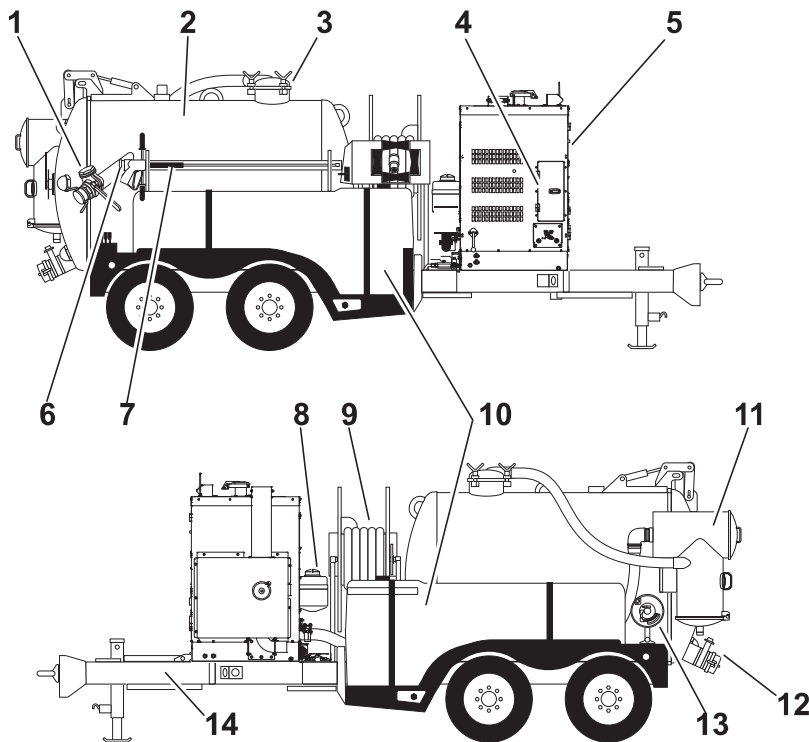

- |                          |   |
|--------------------------|---|
| 1. Inlet valve           | 8. Antifreeze tank                        |
| 2. Vacuum tank           | 9. Vacuum hose reel                       |
| 3. Primary shutoff valve | 10. Water tanks                           |
| 4. Operator's station    | 11. Vacuum filter/secondary shutoff valve |
| 5. Power pack            | 12. Drain/Outlet valve                    |
| 6. Potholing tools       | 13. Hose reel - wash pump                 |
| 7. Water lance           | 14. Tool storage                          |

## FXT60 Unit Components

### 500-Gal (1893-L) Tank

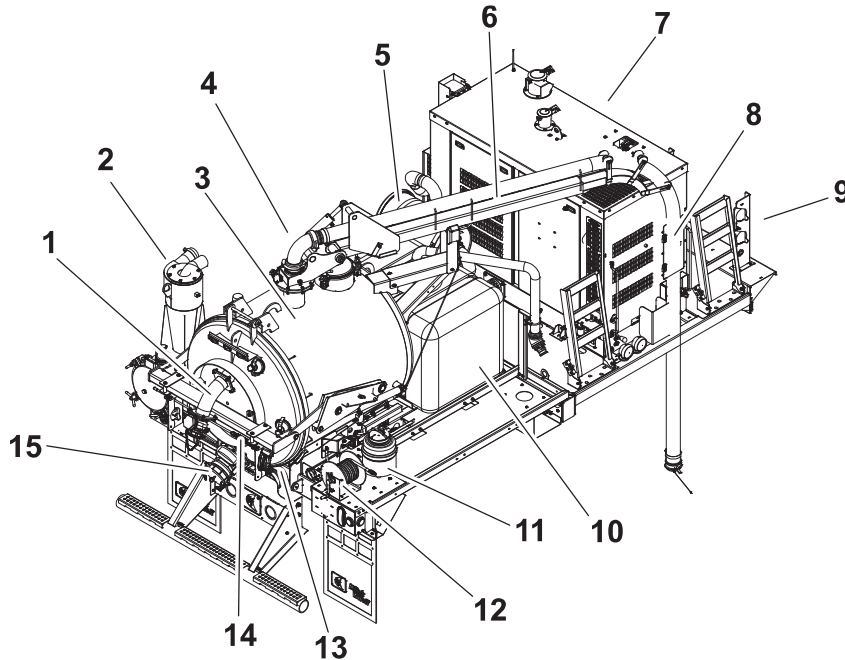

j44om019h.eps

- |  |                            |
|--|----------------------------|
| 1. Inlet valve                           | 9. Tool storage (optional) |
| 2. Cyclonic filter                       | 10. Water tank             |
| 3. Vacuum tank                           | 11. Antifreeze tank        |
| 4. Primary shutoff valve                 | 12. Hose reel              |
| 5. Vacuum filter/secondary shutoff valve | 13. Tool storage           |
| 6. Vacuum boom (optional)                | 14. Water lance            |
| 7. Power pack                            | 15. Drain/Outlet valve     |
| 8. Operator's station                    |                            |

**800-Gal (3028-L) Tank**

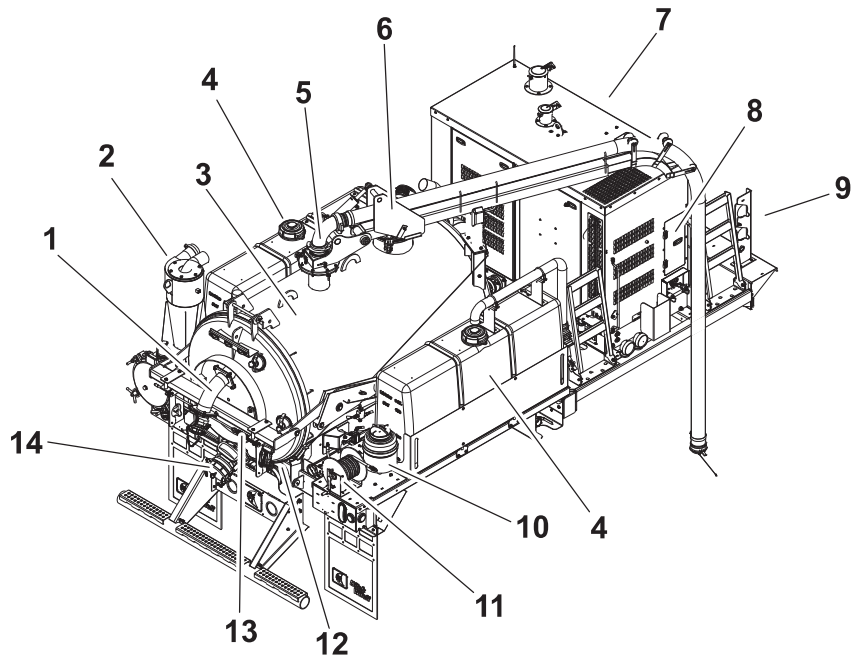

j44om018h.eps

- |                           |                            |
|---------------------------|----------------------------|
| 1. Inlet valve            | 8. Operator's station      |
| 2. Cyclonic filter        | 9. Tool storage (optional) |
| 3. Vacuum tank            | 10. Antifreeze tank        |
| 4. Water tanks            | 11. Vacuum hose reel       |
| 5. Primary shutoff valve  | 12. Tool storage           |
| 6. Vacuum boom (optional) | 13. Water lance            |
| 7. Power pack             | 14. Drain/Outlet valve     |

## FCC Statement



### U.S.

This device complies with Part 15 of the FCC Rules. Operation is subject to the following two conditions: (1) this device may not cause harmful interference, and (2) this device must accept any interference received, including interference that may cause undesired operation.

Changes or modifications not expressly approved by **The Charles Machine Works, Inc.** could void the user's authority to operate the equipment.

Contains **FCC ID**: QLW9-MFS-ERGOF-2G4.

### Canada

This device complies with Industry Canada *license-exempt* RSS standard(s). Operation is subject to the following two conditions: (1) this device may not cause interference, and (2) this device must accept any interference, including interference that may cause undesired operation of the device.

Contains **IC**: 2119B-ERGOF.

Le présent appareil est conforme aux CNR d'Industrie Canada applicables aux appareils radio exempts de licence. L'exploitation est autorisée aux deux conditions suivantes : (1) l'appareil ne doit pas produire de brouillage, et (2) l'appareil doit accepter tout brouillage radioélectrique subi, même si le brouillage est susceptible d'en compromettre le fonctionnement.

Contient **IC**: 2119B-ERGOF.



## Operator Orientation

- |                  |                 |
|------------------|-----------------|
| 1. Front of unit | 3. Rear of unit |
| 2. Right of unit | 4. Left of unit |

Right and left sides of machine are determined by facing towing vehicle.

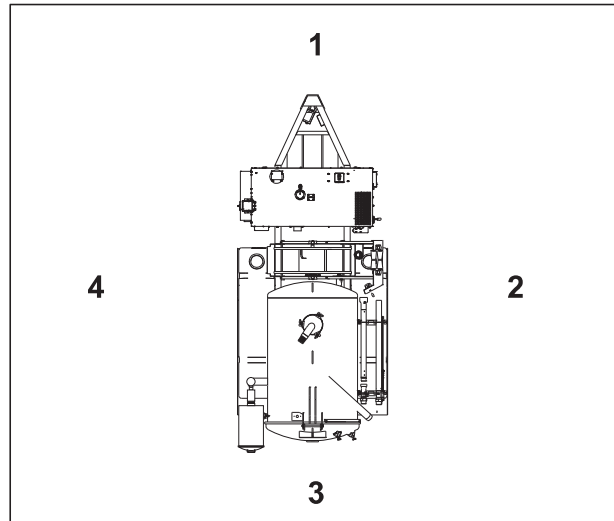

## About This Manual

This manual contains information for the proper use of this machine. See **Operation Overview** for basic operating procedures. Cross references such as "See page 50" will direct you to detailed procedures.

### Bulleted Lists

Bulleted lists provide helpful or important information or contain procedures that do not have to be performed in a specific order.

### Numbered Lists

Numbered lists contain illustration callouts or list steps that must be performed in order.

# Foreword



This manual is an important part of your equipment. It provides safety information and operation instructions to help you use and maintain your Ditch Witch® equipment.

Read this manual before using your equipment. Keep it with the equipment at all times for future reference. If you sell your equipment, be sure to give this manual to the new owner.

If you need a replacement copy, contact your Ditch Witch dealer. If you need assistance in locating a dealer, visit our website at [www.ditchwitch.com](http://www.ditchwitch.com) or write to the following address:

The Charles Machine Works, Inc.  
Attn: Marketing Department  
PO Box 66  
Perry, OK 73077-0066  
USA

The descriptions and specifications in this manual are subject to change without notice. The Charles Machine Works, Inc. reserves the right to improve equipment. Some product improvements may have taken place after this manual was published. For the latest information on Ditch Witch equipment, see your Ditch Witch dealer.

Thank you for buying and using Ditch Witch equipment.

## Reporting Safety Defects

If you believe that your vehicle has a defect which could cause a crash or could cause injury or death, you should immediately inform the National Highway Traffic Safety Administration (NHTSA) in addition to notifying The Charles Machine Works, Inc, Attn: Product Safety Coordinator.

If NHTSA receives similar complaints, it may open an investigation, and if it finds that a safety defect exists in a group of vehicles, it may order a recall and remedy campaign. However, NHTSA cannot become involved in any individual problems between you, your Ditch Witch dealer, or The Charles Machine Works, Inc.

To contact NHTSA you may either call the Auto Safety Hotline toll-free at 1-800-424-9393 (366-0123 in Washington, DC area) or write to:

NHTSA  
U.S. Department of Transportation  
400 7th Street SW (NSA-11)  
Washington, DC 20590

You can also obtain other information about motor vehicle safety from the Hotline.

**FX60/FXT60 Tier 4  
Operator's Manual**

This manual covers the following models: FX60 Tier 4, FXT60 Tier 4.

Issue number 2.0/OM-11/14

Part number 053-2754

Copyright 2014

by The Charles Machine Works, Inc.



, Ditch Witch, and CMW are registered trademarks of The Charles Machine Works, Inc.

This product is covered by the following patent: **U.S.** 8,066,140; other U.S. patents pending.

# Contents



	<b>Overview</b> machine serial number, information about the type of work this machine is designed to perform, basic machine components, and how to use this manual	<b>1</b>
	<b>Foreword</b> part number, revision level, and publication date of this manual, and factory contact information	<b>9</b>
	<b>Safety</b> machine safety alerts and emergency procedures	<b>11</b>
	<b>Controls</b> machine controls, gauges, and indicators and how to use them	<b>31</b>
	<b>Operation Overview</b> an overview for completing a job with this machine: planning, setting up, vacuuming, potholing, and restoring the jobsite; with cross references to detailed procedures	<b>51</b>
	<b>Prepare</b> procedures for inspecting and classifying the jobsite, and preparing the jobsite for work	<b>55</b>
	<b>Transport</b> procedures for lifting and hauling	<b>61</b>
	<b>Vacuum and Pothole</b> procedures for removing debris and potholing utility locations	<b>65</b>
	<b>Complete the Job</b> procedures for restoring the jobsite and rinsing and storing equipment	<b>81</b>
	<b>Service</b> service intervals and instructions for this machine including lubrication, replacement of wear items, and basic maintenance	<b>85</b>
	<b>Specifications</b> machine specifications including weights, measurements, power ratings, and fluid capacities	<b>129</b>
	<b>Support</b> the warranty policy for this machine, and procedures for obtaining warranty consideration and training	<b>143</b>



**Service Record**

a record of major service performed on the machine

**147**

**Appendix**

additional information about Ditch Witch® equipment

**149**

# Safety



## Chapter Contents

<b>Guidelines</b> .....	<b>14</b>
<b>Emergency Procedures</b> .....	<b>15</b>
• Electric Strike Description .....	15
• If an Electric Line is Damaged .....	16
• If a Gas Line is Damaged .....	17
• If a Fiber Optic Cable is Damaged .....	18
• If Machine Catches on Fire .....	18
<b>Safety Alert Classifications</b> .....	<b>19</b>
<b>FX60T4 Machine Safety Alerts</b> .....	<b>20</b>
• Power Unit .....	20
• 800 Gallon Tanks .....	22
• 1200 Gallon Tank .....	24
<b>FXT60T4 Machine Safety Alerts</b> .....	<b>26</b>
• Power Unit .....	26
• Tanks .....	28
<b>FX Filters and Cyclones Safety Alerts</b> .....	<b>30</b>

## Guidelines

Follow these guidelines before operating any jobsite equipment:

- Complete proper training and read operator's manual before using equipment.
- Contact your local One-Call (811 in USA) or the One-Call referral number (888-258-0808 in USA and Canada) to have underground utilities located before digging. Also contact any utilities that do not participate in the One-Call service. Mark proposed path with white paint prior to contacting One-Call or utilities.
- Classify jobsite based on its hazards and use correct tools and machinery, safety equipment, and work methods for jobsite.
- Mark jobsite clearly and keep spectators away.
- Wear personal protective equipment.
- Review jobsite hazards, safety and emergency procedures, and individual responsibilities with all personnel before work begins. Safety videos are available from your Ditch Witch® dealer or at [ditchwitch.com/resources/safety](http://ditchwitch.com/resources/safety).
- Replace missing or damaged safety shields and safety signs.
- Use equipment carefully. Stop operation and investigate anything that does not look or feel right.
- Do not operate unit where flammable gas may be present.
- Contact your Ditch Witch dealer if you have any question about operation, maintenance, or equipment use.
- Complete the equipment checklist located at [www.ditchwitch.com/resources/safety](http://www.ditchwitch.com/resources/safety).

## Emergency Procedures



**WARNING** Jobsite hazards could cause death or serious injury. Use correct equipment and work methods. Use and maintain proper safety equipment. 274-050



Before operating any equipment, review emergency procedures and check that all safety precautions have been taken.

**EMERGENCY SHUTDOWN** - Turn ignition switch to stop position or push remote engine stop button (if equipped).

### Electric Strike Description

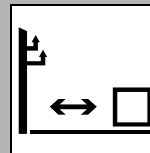

**DANGER** Electric shock. Contacting electric lines will cause death or serious injury. Know location of lines and stay away.

When working near electric cables, remember the following:

- Electricity follows all paths to ground, not just path of least resistance.
- Pipes, hoses, and cables will conduct electricity back to all equipment.
- Low voltage current can injure or kill. Many work-related electrocutions result from contact with less than 440 volts.

Most electric strikes are not noticeable, but indications of a strike include:

- power outage
- smoke
- explosion
- popping noises
- arcing electricity

**If any of these occur, assume an electric strike has occurred.**



## **If an Electric Line is Damaged**

Ditch Witch® If you suspect an electric line has been damaged and you are **on truck or trailer**, DO NOT MOVE. Remain on truck or trailer and take the following actions. The order and degree of action will depend on the situation.

- Warn people nearby that an electric strike has occurred. Instruct them to leave the area and contact utility.
- Do not allow anyone into area until given permission by utility company.
- Do not allow anyone to touch equipment.

If you suspect an electric line has been damaged and you are **off truck or trailer**, DO NOT TOUCH EQUIPMENT. Take the following actions. The order and degree of action will depend on the situation.

- LEAVE AREA. The ground surface may be electrified so take small shuffle steps with feet close together to reduce the hazard of being shocked from one foot to the other.
- Contact utility company to shut off power.
- Do not return to area or allow anyone into area until given permission by utility company.

## If a Gas Line is Damaged



**⚠ WARNING** Fire or explosion possible. Fumes could ignite and cause burns. No smoking, no flame, no spark. 275-419 (2P)



**⚠ WARNING** Explosion possible. Serious injury or equipment damage could occur. Follow directions carefully.

If you suspect a gas line has been damaged, take the following actions. The order and degree of action will depend on the situation.

- Immediately shut off engine(s), if this can be done safely and quickly.
- Remove any ignition source(s), if this can be done safely and quickly.
- Warn others that a gas line has been cut and that they should leave the area.
- Leave jobsite as quickly as possible.
- Immediately call your local emergency phone number and utility company.
- If jobsite is along street, stop traffic from driving near jobsite.
- Do not return to jobsite until given permission by emergency personnel and utility company.

## **If a Fiber Optic Cable is Damaged**

Do not look into cut ends of fiber optic or unidentified cable. Vision damage can occur. Contact utility company.

## **If Machine Catches on Fire**

Perform emergency shutdown procedure and then take the following actions. The order and degree of action will depend on the situation.

- Immediately move battery disconnect switch (if equipped and accessible) to disconnect position.
- If fire is small and fire extinguisher is available, attempt to extinguish fire.
- If fire cannot be extinguished, leave area as quickly as possible and contact emergency personnel.

## Safety Alert Classifications

These classifications and the icons defined on the following pages work together to alert you to situations which could be harmful to you, jobsite bystanders or your equipment. When you see these words and icons in the book or on the machine, carefully read and follow all instructions. **YOUR SAFETY IS AT STAKE.**



Watch for the three safety alert levels: **DANGER**, **WARNING** and **CAUTION**. Learn what each level means.

 **DANGER** indicates a hazardous situation that, if not avoided, will result in death or serious injury. This signal word is to be limited to the most extreme situations.

 **WARNING** indicates a hazardous situation that, if not avoided, could result in death or serious injury.

 **CAUTION** indicates a hazardous situation that, if not avoided, could result in minor or moderate injury.

Watch for two other words: **NOTICE** and **IMPORTANT**.

**NOTICE** indicates information considered important, but not hazard-related (e.g., messages relating to property damage).

**IMPORTANT** can help you do a better job or make your job easier in some way.

# FX60T4 Machine Safety Alerts

## Power Unit

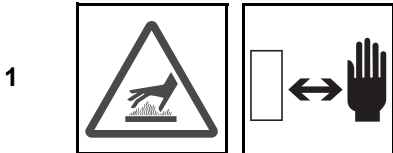
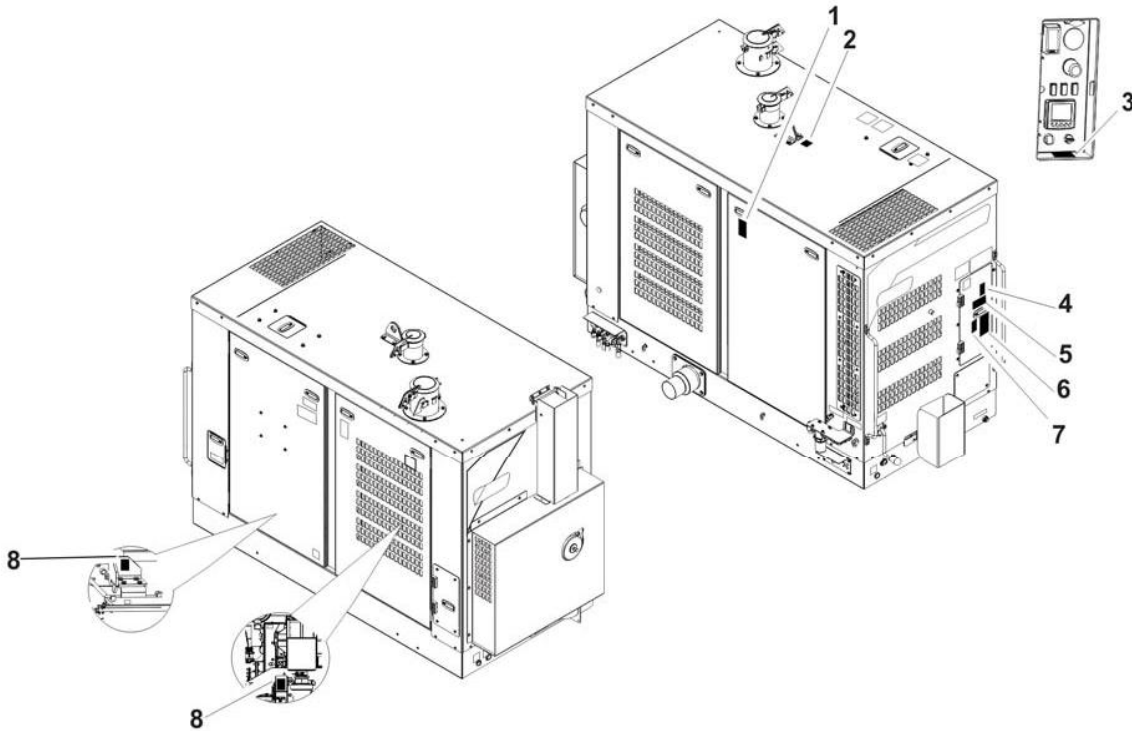

**CAUTION** Hot parts may cause burns. Do not touch until cool or wear gloves. 275-355 (2-P)



Lift point. See Transport chapter for more information.



**WARNING** Read operator's manual. Know how to use all controls. Your safety is at stake. 273-475



**CAUTION** Exposure to high noise levels may cause hearing loss. Wear hearing protection. 700-009 (2-P)

5

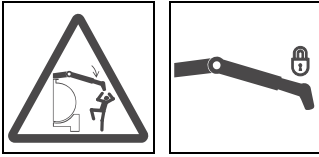

**⚠ WARNING** Incorrect boom procedures could result in serious injury or death. Lock boom before transporting or tilting. 270-1982

6



**⚠ CAUTION** Flying objects thrown by machine may strike people. Wear safety glasses and hard hat. 275-193

7

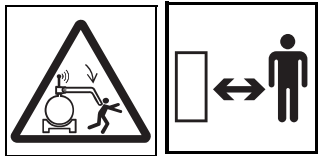

**⚠ CAUTION** Equipment can be operated by remote control. Stay away. 270-5739

8

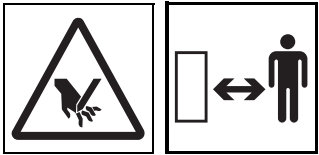

**⚠ WARNING** Moving parts could cut off hand or foot. Stay away. 275-184, 273-437



**800 Gallon Tanks**

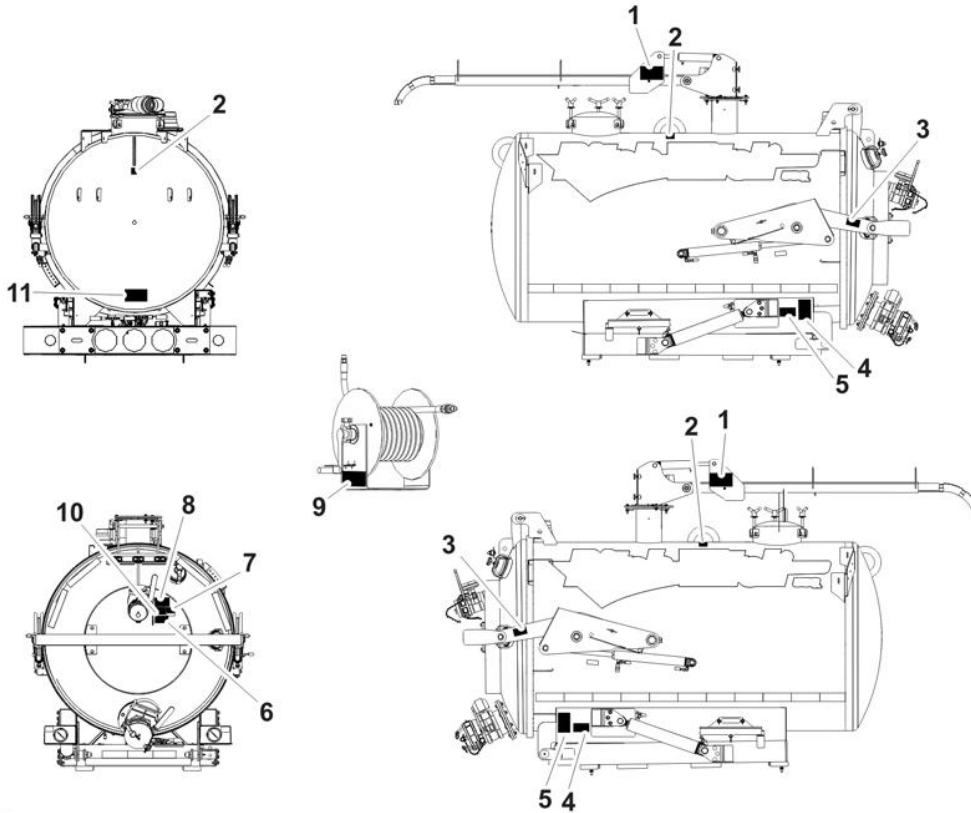

Decal\_FX\_Tanks

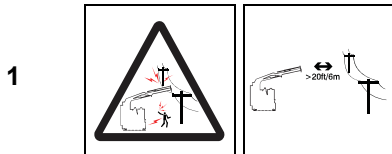

**⚠ DANGER** Do not get boom near power lines. Death or serious injury will occur. Keep required distance between boom and power lines. Use a spotter. 270-1983





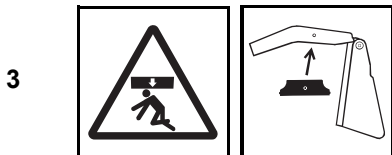





Lift point. See Transport chapter for more information.

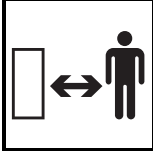

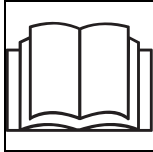
**⚠ WARNING** Crushing weight can cause death or serious injury. Pin door lock on linkage before servicing. 270-5216

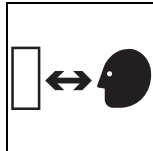

**⚠ WARNING** Crushing weight. Place cylinder lock on extended cylinder and secure. 273-231

5			<b>⚠ WARNING</b> Moving parts could cut off hand or foot. Stay away. 275-184, 273-437
6			<b>⚠ WARNING</b> Contents under pressure. Relieve pressure before opening. Death or injury could occur. 270-2732
7			<b>⚠ DANGER</b> Vacuum can suffocate. Keep hose end away from face. 273-205
8			<b>⚠ WARNING</b> Fire or explosion possible. Do not vacuum flammable or combustible substances. 273-483
9			<b>⚠ WARNING</b> Pressurized fluid or air could pierce skin and cause severe injury. Refer to operator's manual for proper use. 270-6035
10			<b>⚠ DANGER</b> Confined space will cause suffocation. Use proper procedures for entering or stay away. 273-200
11			<b>⚠ WARNING</b> Crushing weight could cause death or serious injury. Stay away. 275-326





**1200 Gallon Tank**

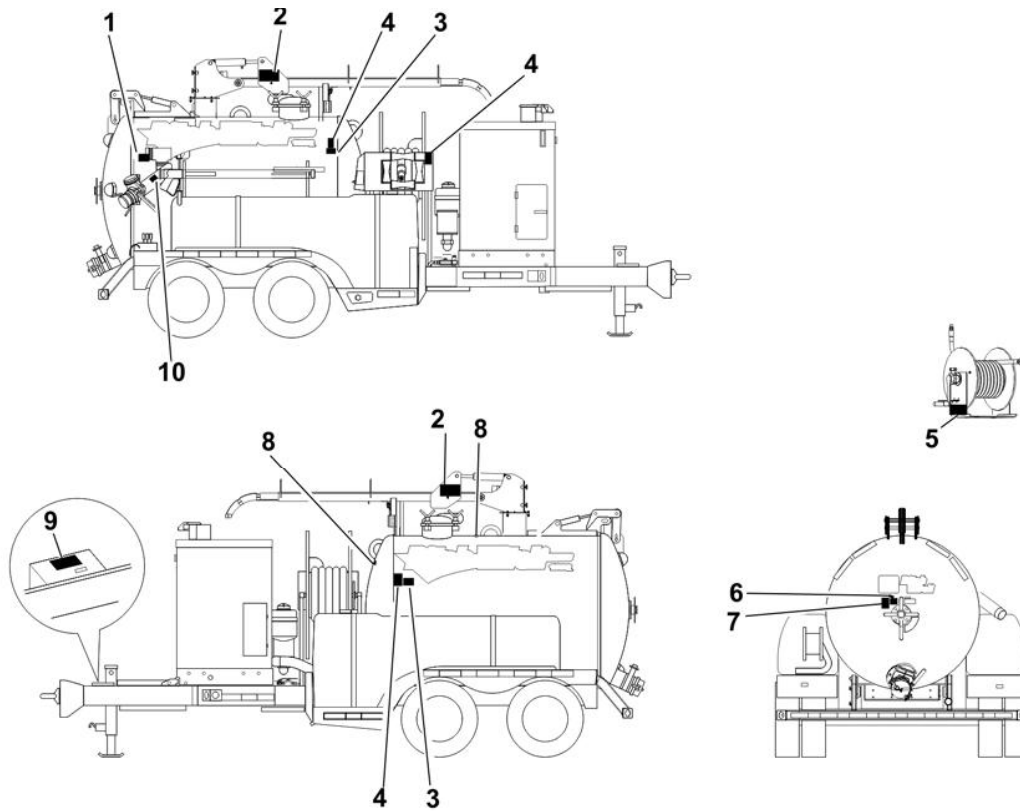

Decal FX Tank 1200nl

1

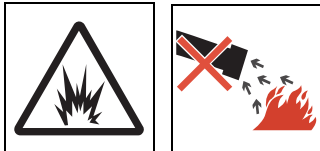

**⚠ WARNING** Fire or explosion possible. Do not vacuum flammable or combustible substances. 273-483

2

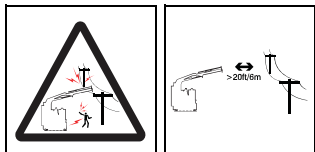

**⚠ DANGER** Do not get boom near power lines. Death or serious injury will occur. Keep required distance between boom and power lines. Use a spotter. 270-1983

3

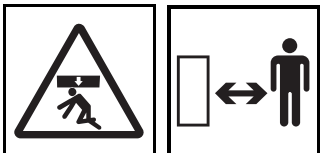

**⚠ WARNING** Crushing weight could cause death or serious injury. Stay away. 275-326

4

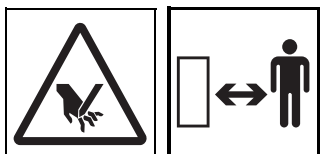

**⚠ WARNING** Moving parts could cut off hand or foot. Stay away. 275-184, 273-437

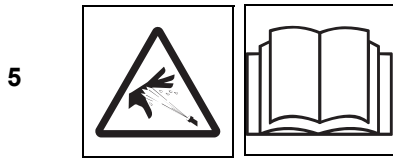

**⚠ WARNING** Pressurized fluid or air could pierce skin and cause severe injury. Refer to operator's manual for proper use. 270-6035



**⚠ WARNING** Contents under pressure. Relieve pressure before opening. Death or injury could occur. 270-2732

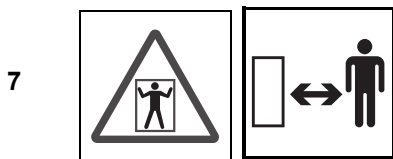

**⚠ DANGER** Confined space will cause suffocation. Use proper procedures for entering or stay away. 273-200



Lift point. See Transport chapter for more information.



**⚠ WARNING** 275-146

- Secure equipment and accessories with chain and binder.
- Check brakes and lights prior to use.
- Use proper size coupler.
- Maintain adequate distance for stopping and passing vehicles.
- Block wheels when parked.
- Check tire condition and inflation frequently.
- Failure to follow these rules may result in personal injury.

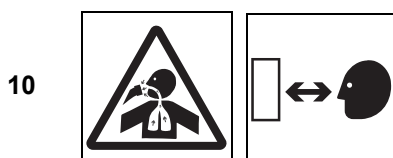

**⚠ DANGER** Vacuum can suffocate. Keep hose end away from face. 273-205



# FXT60T4 Machine Safety Alerts

## Power Unit

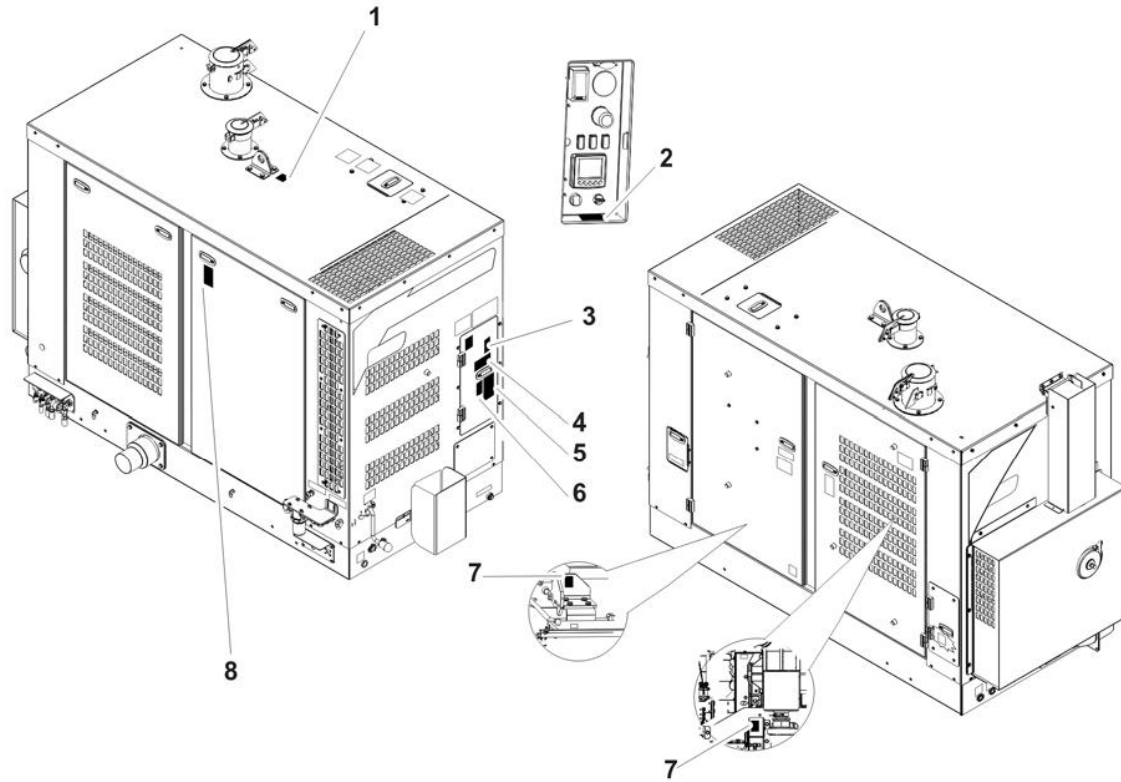

Decal\_FX50T4





Lift point. See Transport chapter for more information.



**⚠ WARNING** Read operator's manual. Know how to use all controls. Your safety is at stake. 273-475





**⚠ CAUTION** Exposure to high noise levels may cause hearing loss. Wear hearing protection. 700-009 (2-P)

4   **⚠ WARNING** Incorrect boom procedures could result in serious injury or death. Lock boom before transporting or tilting. 270-1982

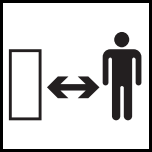
5   **⚠ CAUTION** Flying objects thrown by machine may strike people. Wear safety glasses and hard hat. 275-193

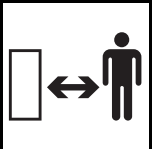
6   **⚠ CAUTION** Equipment can be operated by remote control. Stay away. 270-5739

7   **⚠ WARNING** Moving parts could cut off hand or foot. Stay away. 275-184, 273-437

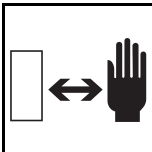
8   **⚠ CAUTION** Hot parts may cause burns. Do not touch until cool or wear gloves. 275-355 (2-P)



**Tanks**

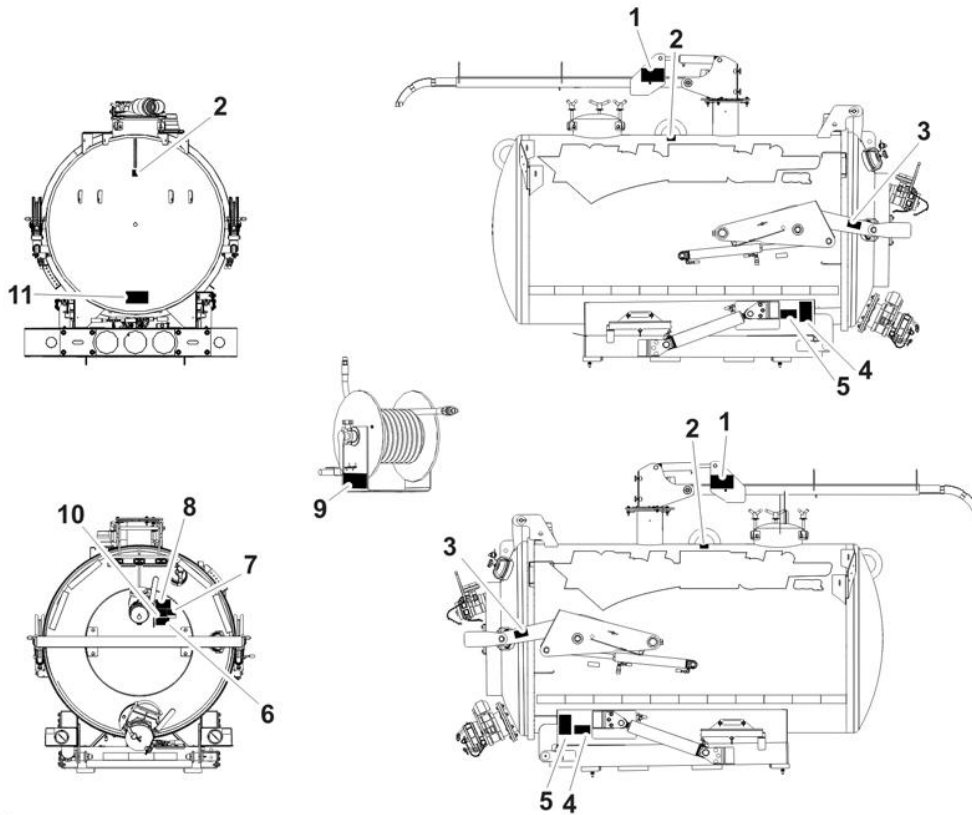

Decal\_FX\_Tanks

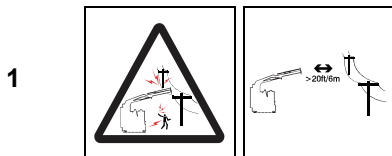

**⚠ DANGER** Do not get boom near power lines. Death or serious injury will occur. Keep required distance between boom and power lines. Use a spotter. 270-1983



Lift point. See Transport chapter for more information.

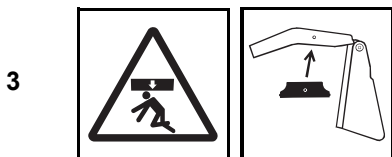

**⚠ WARNING** Crushing weight can cause death or serious injury. Pin door lock on linkage before servicing. 270-5216



**⚠ WARNING** Crushing weight. Place cylinder lock on extended cylinder and secure. 273-231

5			<b>⚠ WARNING</b> Moving parts could cut off hand or foot. Stay away. 275-184, 273-437
6			<b>⚠ WARNING</b> Contents under pressure. Relieve pressure before opening. Death or injury could occur. 270-2732
7			<b>⚠ DANGER</b> Vacuum can suffocate. Keep hose end away from face. 273-205
8			<b>⚠ WARNING</b> Fire or explosion possible. Do not vacuum flammable or combustible substances. 273-483
9			<b>⚠ WARNING</b> Pressurized fluid or air could pierce skin and cause severe injury. Refer to operator's manual for proper use. 270-6035
10			<b>⚠ DANGER</b> Confined space will cause suffocation. Use proper procedures for entering or stay away. 273-200
11			<b>⚠ WARNING</b> Crushing weight could cause death or serious injury. Stay away. 275-326



## FX Filters and Cyclones Safety Alerts

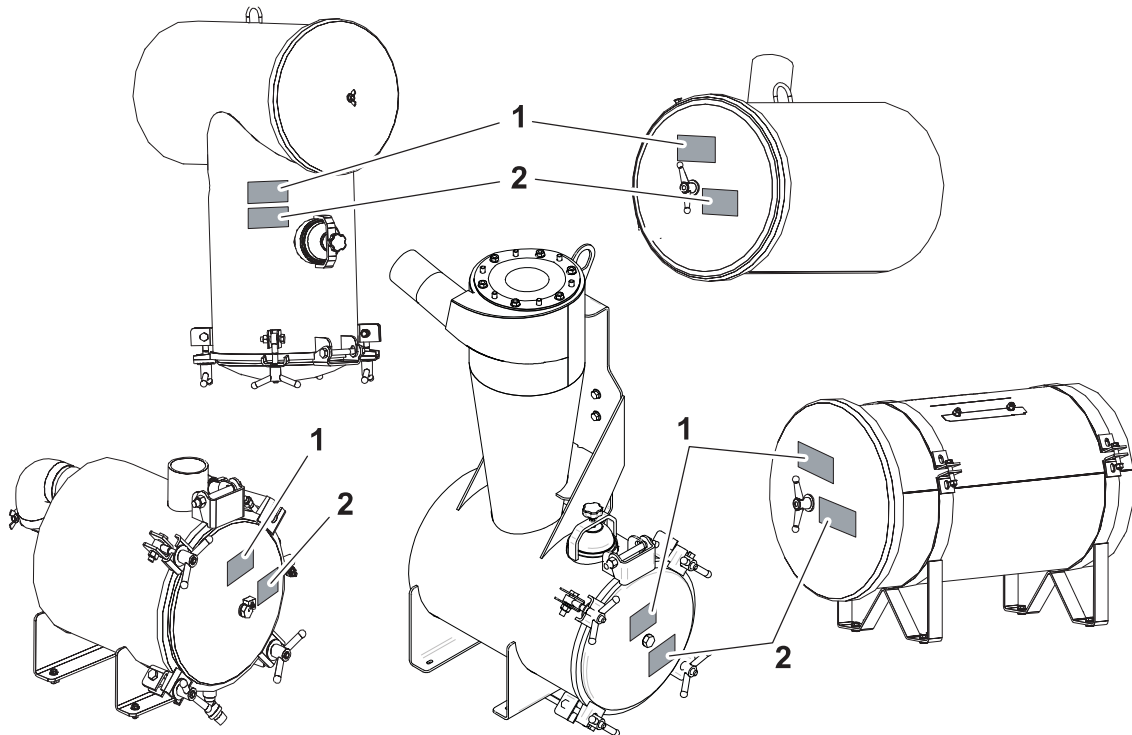

FX\_Filters\_&\_Cyclones.eps

1

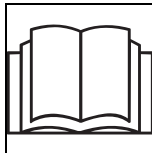

**⚠ WARNING** Contents under pressure. Relieve pressure before opening. Death or injury could occur. 270-2732

2

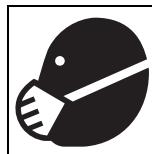

**⚠ CAUTION** Use breathing protection when exposed to silica dust. 270-4952

---

# Controls

## Chapter Contents

<b>Power Pack</b> .....	<b>32</b>
• Controls and Connectors .....	32
• Display .....	36
<b>800 Tank</b> .....	<b>39</b>
• Tethered Controller .....	39
• Machine Controls .....	40
<b>1200 Tank</b> .....	<b>42</b>
• Tank Controls .....	42
• Machine Controls .....	44
<b>Vacuum Boom (optional)</b> .....	<b>47</b>
<b>Wireless Control Module</b> .....	<b>49</b>





# Power Pack

## Controls and Connectors

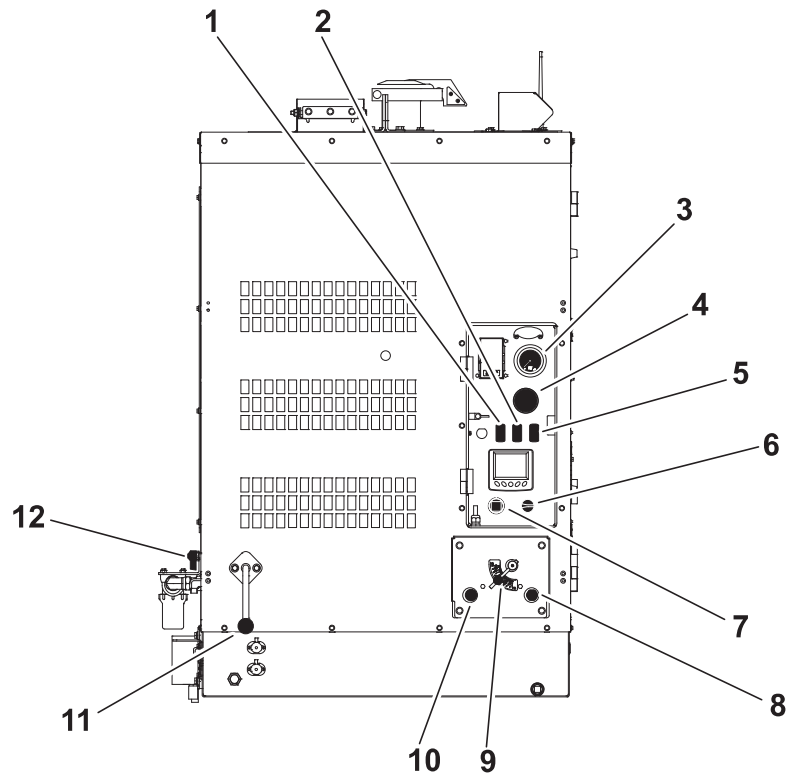

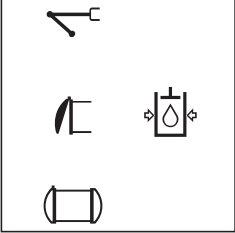
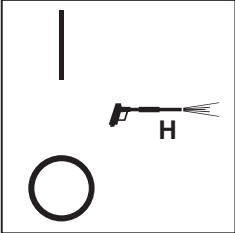
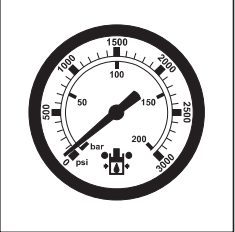
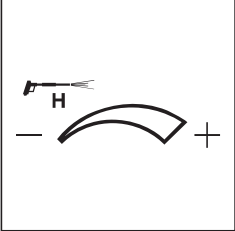

j43om005h.eps

- |                              |                                |
|------------------------------|--------------------------------|
| 1. Hydraulic function switch | 7. Throttle                    |
| 2. Water pump switch         | 8. Hydraulic return connector  |
| 3. Water pressure gauge      | 9. Hydraulic flow control      |
| 4. Water pressure control    | 10. Hydraulic supply connector |
| 5. Light switch              | 11. Flow direction control     |
| 6. Ignition switch           | 12. Battery disconnect switch  |

Item	Description	Notes
<p><b>1. Hydraulic function switch</b></p>  <p>c00ic526h.eps</p>	<p>To direct hydraulic power to the optional boom function, press top.</p> <p>To direct hydraulic power to the door function, move to center position.</p> <p>To direct hydraulic power to the tank tilt function, press bottom.</p>	
<p><b>2. Water pump switch</b></p>  <p>c00ic062Le.eps</p>	<p>To turn on water pump, press top.</p> <p>To turn off water pump, press bottom.</p>	
<p><b>3. Water pressure gauge</b></p>  <p>c00ic118h.eps</p>	<p>Displays water pressure when water pressure switch is on and water lance is in use.</p>	
<p><b>4. Water pressure control</b></p>  <p>c00ic527h.eps</p>	<p>To increase water pressure, turn clockwise.</p> <p>To decrease water pressure, turn counterclockwise.</p>	

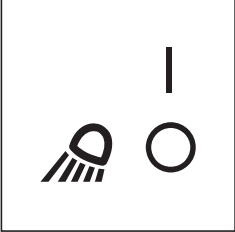
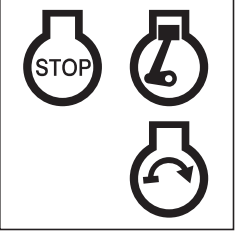

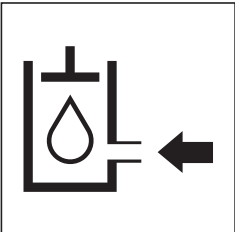
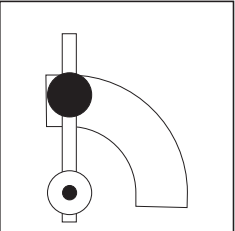
Item	Description	Notes
<p><b>5. Light switch</b></p>  <p>c00ic258h.eps</p>	<p>To turn on, press top.</p> <p>To turn off, press bottom.</p>	
<p><b>6. Ignition switch</b></p>  <p>c00ic065h.eps</p>	<p>To start engine, insert key and turn clockwise.</p> <p>To stop engine, turn key counterclockwise.</p>	<p><b>IMPORTANT:</b> When engine is on, blower operates and vacuum is present at tank inlet.</p>
<p><b>7. Throttle</b></p>  <p>c00ic116h.eps</p>	<p>To increase engine speed, rotate clockwise.</p> <p>To decrease engine speed, rotate counterclockwise.</p>	
<p><b>8. Hydraulic return connector</b></p>  <p>c00ic529h.eps</p>	<p>To operate hydraulic power tools with power pack hydraulic system, connect hydraulic return hose to connector.</p>	<p><b>IMPORTANT:</b> Connect return hose before connecting supply hose.</p>
<p><b>9. Hydraulic flow control</b></p>  <p>c00ic136h.eps</p>	<p>To increase hydraulic flow to tool, move handle toward horizontal position.</p> <p>To decrease hydraulic flow to tool, move handle toward vertical position.</p>	<p>Maximum output is 7.5 gpm (28 L/min) at 2000 psi (138 bar).</p> <p><b>IMPORTANT:</b></p> <ul style="list-style-type: none"> <li>• Stop flow before connecting or disconnecting hydraulic tools.</li> <li>• Leave flow at 0 unless hoses are connected.</li> </ul>

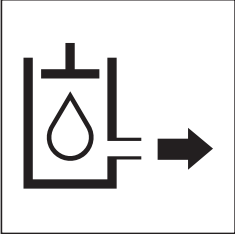
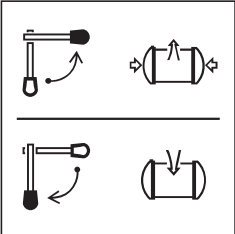
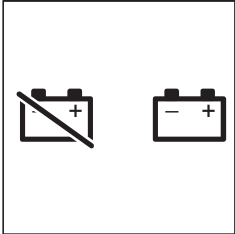
Item	Description	Notes
<p><b>10. Hydraulic supply connector</b></p>  <p><small>c00ic528h.eps</small></p>	<p>To operate hydraulic power tools with power pack hydraulic system, connect hydraulic supply hose to connector.</p>	<p><b>IMPORTANT:</b> Connect return hose before connecting supply hose.</p>
<p><b>11. Flow direction control</b></p>  <p><small>c00ic605h.eps</small></p>	<p>To operate in reverse flow mode, turn counterclockwise.</p> <p>To operate in vacuum mode, turn clockwise.</p>	<p>Use reverse flow to unload tank contents to another tank. Operate in reverse flow mode only when drain/outlet valve is open.</p>
<p><b>12. Battery disconnect switch</b></p>  <p><small>c00ic063t.eps</small></p>	<p>To connect, turn clockwise.</p> <p>To disconnect, turn counterclockwise.</p>	<p><b>IMPORTANT:</b> Use battery disconnect switch when servicing, welding, and during long-term storage.</p>



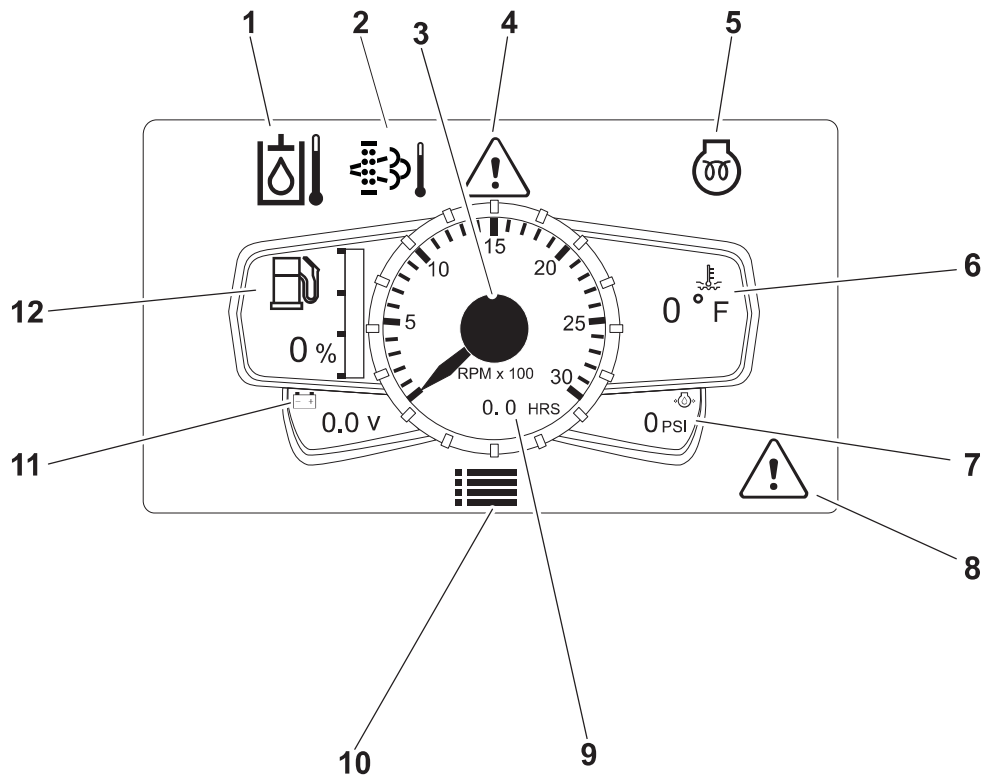

**Display**

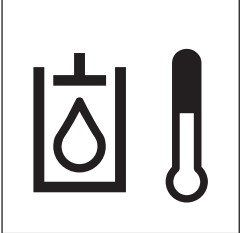
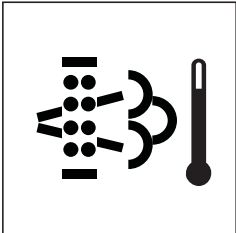

j43om042h.eps

- |  |                                  |
|--|----------------------------------|
| 1. Hydraulic fluid temperature indicator | 7. Engine oil pressure indicator |
| 2. Blower temperature indicator          | 8. Diagnostics menu button       |
| 3. Engine speed (RPM)                    | 9. Hourmeter                     |
| 4. Diagnostic message indicator          | 10. Settings menu button         |
| 5. Wait-to-start indicator               | 11. Electrical system voltage    |
| 6. Engine coolant temperature indicator  | 12. Fuel gauge                   |

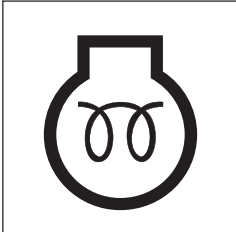
Item	Description	Notes
<p><b>1. Hydraulic fluid temperature indicator</b></p>  <p>c00ic023h.eps</p>	<p>Indicates hydraulic fluid temperature is above 215°F (102°C).</p>	<p>Engine will stop.</p> <p>Check hydraulic fluid level.</p>
<p><b>2. Blower temperature indicator</b></p>  <p>c00ic685h.eps</p>	<p>Indicates blower discharge temperature is above 335°F (168°C).</p>	<p>Engine will stop.</p> <ol style="list-style-type: none"> <li>1. Check for air flow obstructions.</li> <li>2. Let blower cool before restarting.</li> </ol>
<p><b>3. Engine speed (RPM)</b></p>	<p>Displays engine RPM.</p>	
<p><b>4. Diagnostic message indicator</b></p>	<p> indicates a warning code</p> <p> indicates a stop code</p>	
<p><b>5. Wait-to-start indicator</b></p>  <p>c00ic180h.eps</p>	<p>Indicates glow plugs are operating.</p> <p>Wait until light goes off before starting engine. See "Cold Start Procedure" on page 57.</p>	<p><b>To help avoid injury:</b> Do not use ether or starting fluid.</p>

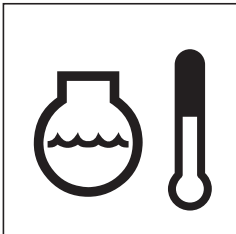
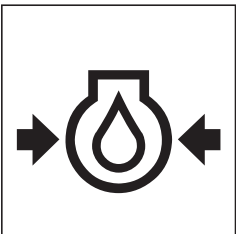
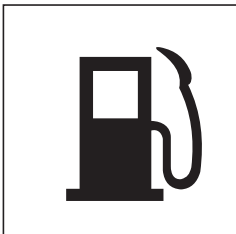

Item	Description	Notes
<b>6. Engine coolant temperature indicator</b>  <small>c00ic120h.eps</small>	Indicates cooling system fluid is overheated.	Engine will stop.  1. Let engine cool.  2. Check cooling system fluid level.
<b>7. Engine oil pressure indicator</b>  <small>c00ic119h.eps</small>	Indicates engine oil pressure is low.  Also lights briefly when engine is started.	Engine will stop.  1. Check oil level.  2. Check for leaks before starting engine.
<b>8. Diagnostics menu button</b>	Press button below icon to go to the Diagnostics menu.	
<b>9. Hourmeter</b>	Displays engine operating time.	Hourmeter runs when ignition switch is on.  Use these times to schedule service.
<b>10. Settings menu button</b>	Press button below icon to go to the Settings menu.	
<b>11. Electrical system voltage</b>	Displays system voltage.	
<b>12. Fuel gauge</b>  <small>c00ic637h.eps</small>	Displays fuel level in tank.	Use low sulfur or ultra low sulfur diesel fuel only.  In temperatures below 40° F (4° C), use #1 diesel fuel.  Tank holds 24 gal (94 L).

**IMPORTANT:** Press any button from the main gauge screen to access menu.

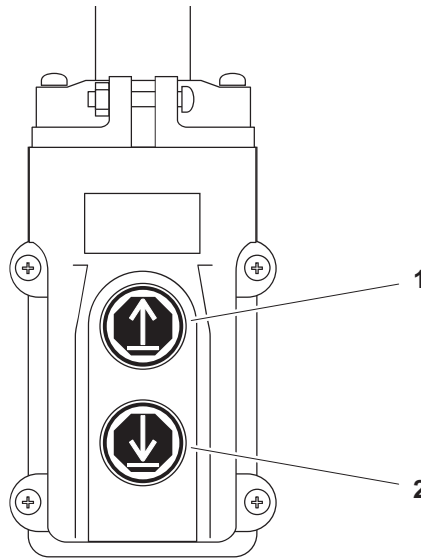

# 800 Tanks

## Tethered Controller



j08om082h.eps



Item	Description	Notes
<p><b>Tethered tank control</b></p> <div data-bbox="260 1223 496 1458">  <p>c00ic174h.eps</p> </div> <div data-bbox="260 1480 496 1715">  <p>c00ic175h.eps</p> </div>	<p>To lift and lower tank, set hydraulic function switch to the tank position, then</p> <ul style="list-style-type: none"> <li>To lift tank, press UP.</li> <li>To lower tank, press DOWN.</li> </ul> <p>To open and close tank door, set hydraulic function switch to the door position, then</p> <ul style="list-style-type: none"> <li>To open door, press UP.</li> <li>To close door, press DOWN.</li> </ul>	<p><b>Note:</b> The vacuum boom uses a different tethered controller. See page 47 and page 49.</p> <p><b>IMPORTANT:</b> These functions are also included on the wireless control module.</p>



**Machine Controls**

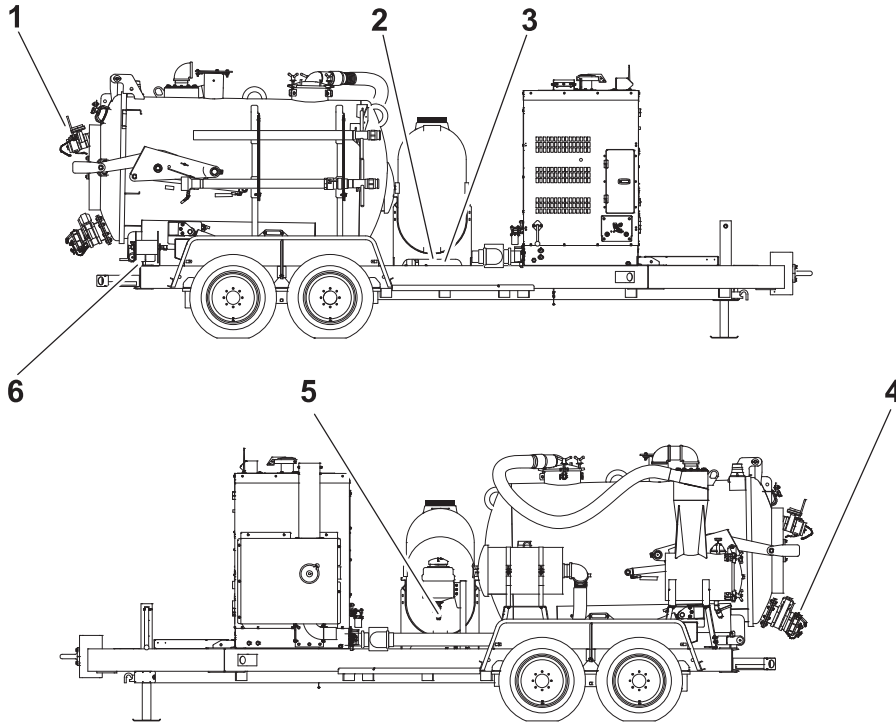

j43om007h.eps

- |                            |                                 |
|----------------------------|---------------------------------|
| 1. Inlet valve             | 4. Drain/Outlet valve           |
| 2. Water tank drain        | 5. Antifreeze tank supply valve |
| 3. Water tank supply valve | 6. Vacuum gauge                 |

Item	Description	Notes
<p>1. Inlet valve</p> <div style="border: 1px solid black; padding: 10px; text-align: center;"> <p><b>CLOSE</b></p> <p>↑</p> <p>○</p> <p>↓</p> <p><b>OPEN</b></p> </div> <p>c00ic127h.eps</p>	<p>To close valve (stop suction), rotate up.</p> <p>To open valve (start suction), rotate down.</p>	

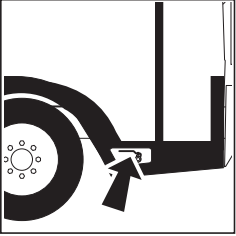
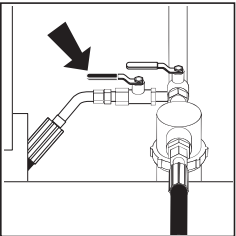
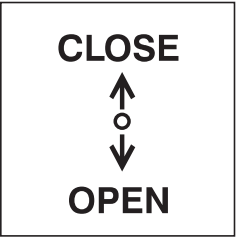
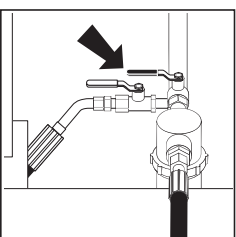
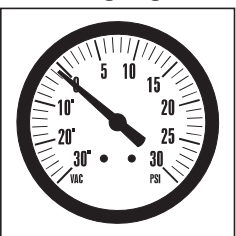
Item	Description	Notes
<p><b>2. Water tank drain</b></p>  <p>c00ic132h.eps</p>	<p>To drain tank, open valve.</p> <p>Close valve when tank is empty.</p>	
<p><b>3. Water tank supply valve</b></p>  <p>c00ic129h.eps</p>	<p>To open valve (send water from the water tank through the pump and water lance), rotate counterclockwise.</p> <p>To close valve (stop water flow), rotate clockwise.</p>	<p><b>IMPORTANT:</b> Water tank supply valve or antifreeze supply valve must be open when pump is running or pump will be damaged.</p>
<p><b>4. Drain/Outlet valve</b></p>  <p>c00ic127h.eps</p>	<p>To drain tank, rotate down.</p> <p>To close drain, rotate up.</p>	
<p><b>5. Antifreeze tank supply valve</b></p>  <p>c00ic130h.eps</p>	<p>To open valve (send antifreeze through pump and water lance), rotate counterclockwise.</p> <p>To close valve (stop antifreeze flow), rotate clockwise.</p>	<p><b>IMPORTANT:</b> Water tank supply valve or antifreeze supply valve must be open when pump is running or pump will be damaged.</p>
<p><b>6. Vacuum gauge</b></p>  <p>c00ic131h.eps</p>	<p>Displays blower vacuum reading in inches of mercury. Vacuum relief valve opens when vacuum reaches 16" (406 mm).</p>	



# 1200 Tank

## Tank Controls

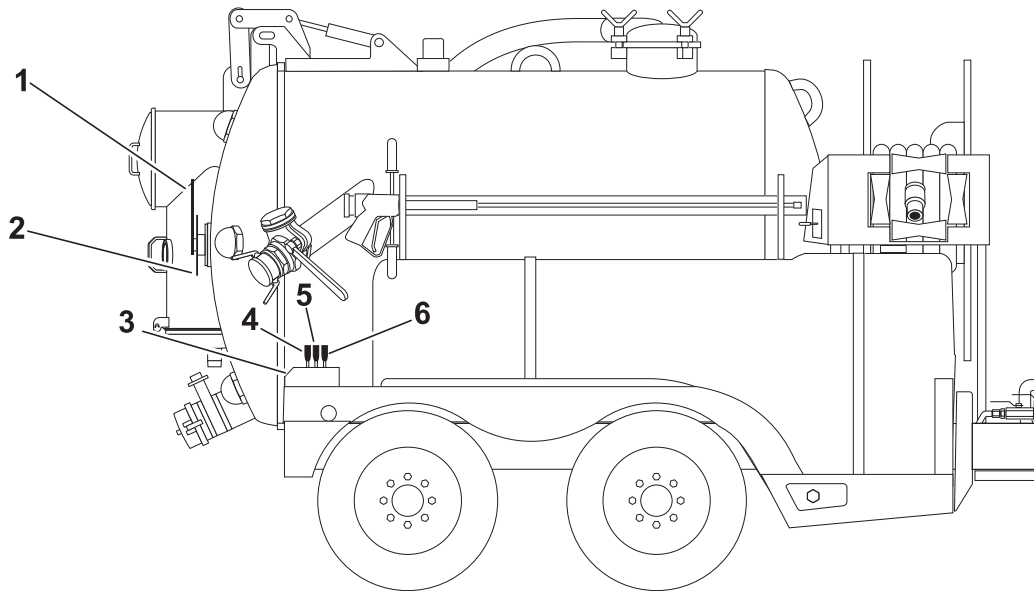

j08om012h.eps

- |                             |                           |
|-----------------------------|---------------------------|
| 1. Tank door lock           | 4. Tank lift control      |
| 2. Tank door handle         | 5. Tank door lift control |
| 3. Door seal pressure gauge | 6. Door seal control      |

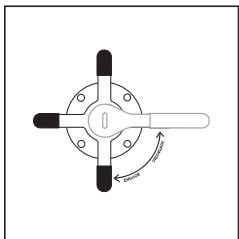
Item	Description	Notes
<b>1. Tank door lock</b>  <p>c00ic126h.eps</p>	To lock vacuum tank door, turn clockwise until it stops.  To unlock door, turn counterclockwise.	

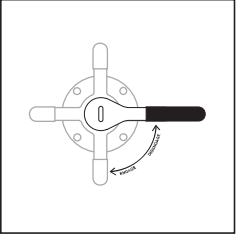
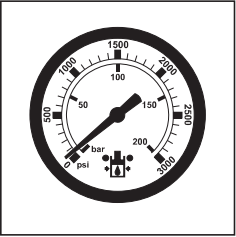
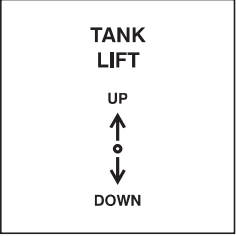
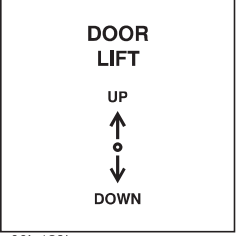
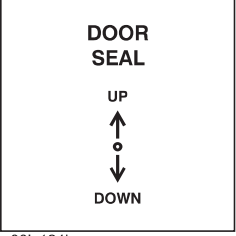
Item	Description	Notes
<p><b>2. Tank door handle</b></p>  <p>c00ic125h.eps</p>	<p>To engage tank door, push and turn 90° clockwise.</p> <p>To disengage tank door, turn 90° counterclockwise and pull.</p>	<p><b>IMPORTANT:</b></p> <ul style="list-style-type: none"> <li>• Tank door must be unlocked before tank door handle will work.</li> <li>• Door handle must be horizontal to push/pull door handle.</li> </ul>
<p><b>3. Door seal pressure gauge</b></p>  <p>c00ic118h.eps</p>	<p>Displays door seal pressure reading. Door is fully sealed when reading reaches 2400 psi (165 bar).</p>	
<p><b>4. Tank lift control</b></p>  <p>c00ic122h.eps</p>	<p>To raise vacuum tank, push up.</p> <p>To lower tank, pull down.</p>	<p><b>IMPORTANT:</b></p> <ul style="list-style-type: none"> <li>• Do not operate tank lift while trailer is unhitched.</li> <li>• This function is also included on the wireless control module.</li> </ul>
<p><b>5. Tank door lift control</b></p>  <p>c00ic123h.eps</p>	<p>To raise tank door, push up.</p> <p>To lower tank door, pull down.</p>	<p><b>IMPORTANT:</b> This function is also included on the wireless control module.</p>
<p><b>6. Door seal control</b></p>  <p>c00ic124h.eps</p>	<p>To seal tank door, push up.</p> <p>To unseal tank door, push down.</p>	



**Machine Controls**

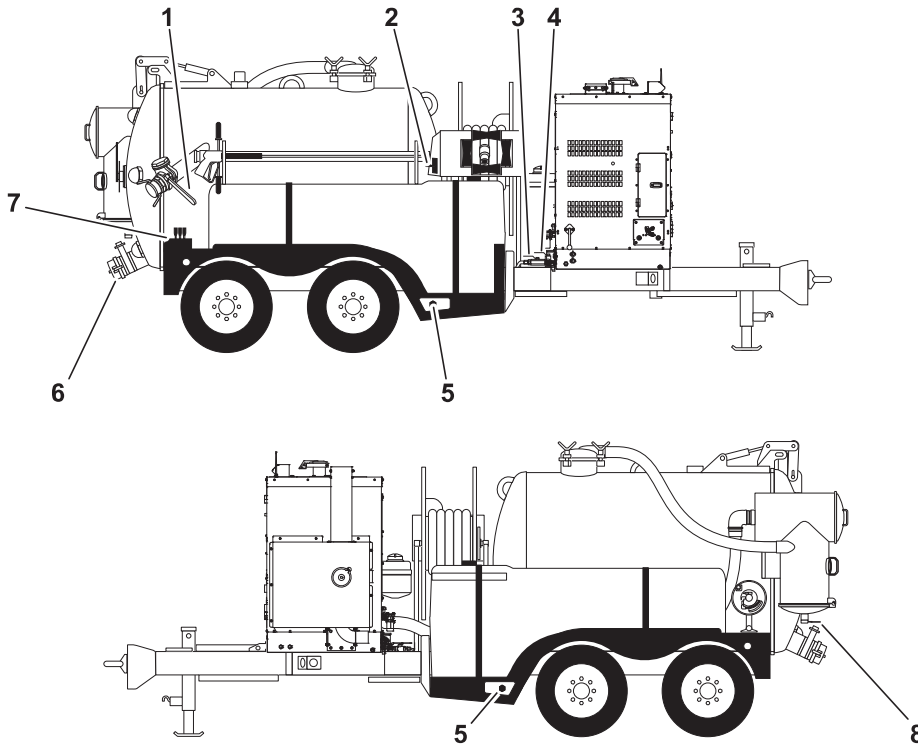

j430m008h.eps

- |                                 |                        |
|---------------------------------|------------------------|
| 1. Inlet valve                  | 5. Water tank drain    |
| 2. Vacuum hose reel control     | 6. Drain/Outlet valve  |
| 3. Water tank supply valve      | 7. Vacuum gauge        |
| 4. Antifreeze tank supply valve | 8. Vacuum filter drain |

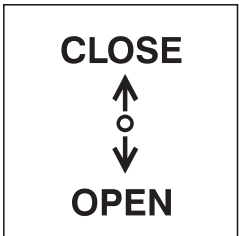
Item	Description	Notes
<b>1. Inlet valve</b> 	To close valve (stop suction), rotate up.  To open valve (start suction), rotate down.	

c00ic127h.eps

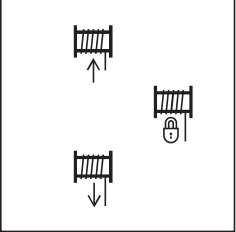
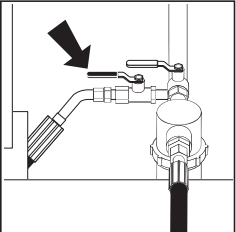
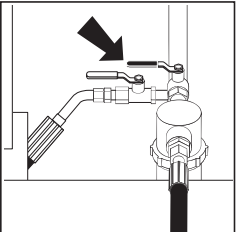
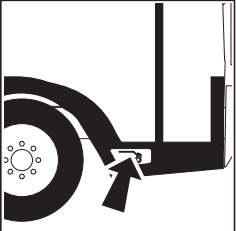
Item	Description	Notes
<p><b>2. Vacuum hose reel control</b></p>  <p>c00ic128h.eps</p>	<p>To wind vacuum hose, push up.</p> <p>To unwind vacuum hose, pull down.</p>	
<p><b>3. Water tank supply valve</b></p>  <p>c00ic129h.eps</p>	<p>To open valve (send water from the water tank through the pump and water lance), rotate counterclockwise.</p> <p>To close valve (stop water flow), rotate clockwise.</p>	
<p><b>4. Antifreeze tank supply valve</b></p>  <p>c00ic130h.eps</p>	<p>To open valve (send antifreeze through pump and water lance), rotate counterclockwise.</p> <p>To close valve (stop antifreeze flow), rotate clockwise.</p>	
<p><b>5. Water tank drain</b></p>  <p>c00ic132h.eps</p>	<p>To drain tank, open valve.</p> <p>Close valve when tank is empty.</p>	

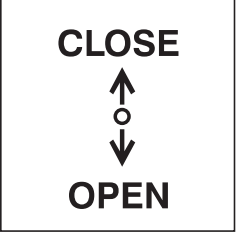
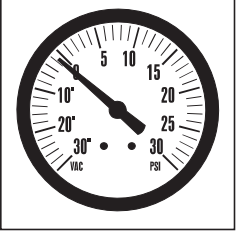
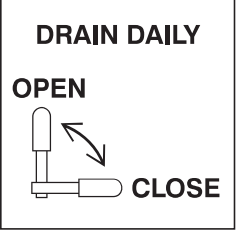

Item	Description	Notes
<p><b>6. Drain/Outlet valve</b></p>  <p><small>c00ic127h.eps</small></p>	<p>To drain tank, rotate down.</p> <p>To close drain, rotate up.</p>	
<p><b>7. Vacuum gauge</b></p>  <p><small>c00ic131h.eps</small></p>	<p>Displays blower vacuum reading in inches of mercury. Vacuum relief valve opens when vacuum reaches 16" (406 mm).</p>	
<p><b>8. Vacuum filter drain</b></p>  <p><small>c00ic133h.eps</small></p>	<p>To drain vacuum filter canister, rotate up.</p> <p>To close drain, rotate down.</p>	

## Vacuum Boom (optional)

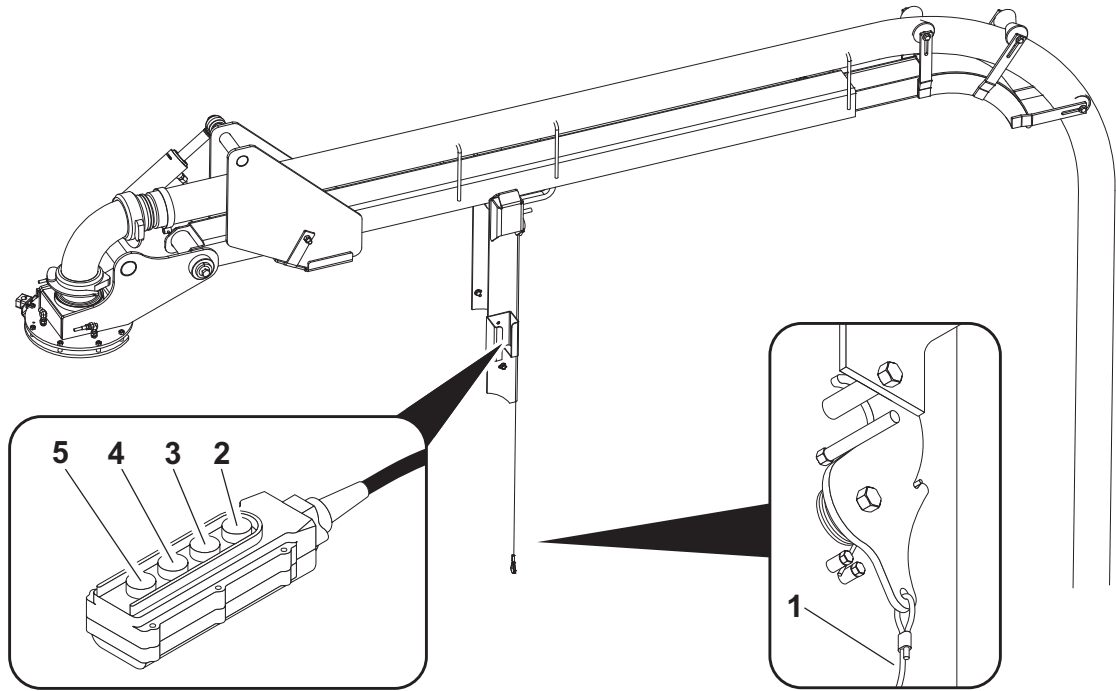

j35om053h.eps

- 1. Boom latch
- 2. Boom up
- 3. Boom down
- 4. Boom retract
- 5. Boom extend

**IMPORTANT:** The vacuum boom can be controlled with the wireless control module or the tethered controller.

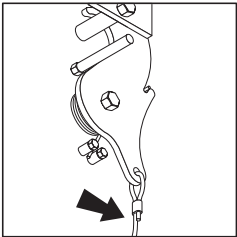
Item	Description	Notes
<b>1. Boom latch</b>  <p>j23om010a.eps</p>	<p>Pull cable to open latch and release boom from saddle.</p> <p>Push boom into latch to lock boom into saddle.</p>	

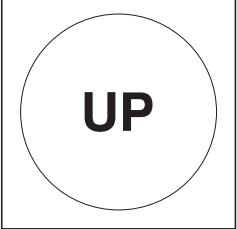
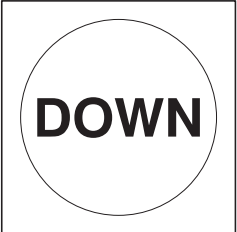
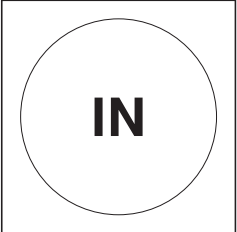
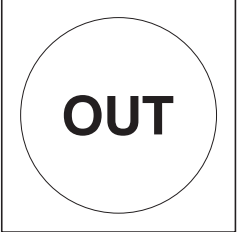

Item	Description	Notes
<p><b>2. Boom up</b></p>  <p><small>c00ic122a.eps</small></p>	<p>To raise boom, press.</p> <p>To stop movement, release.</p>	<p><b>NOTICE:</b> Do not use boom to raise or lower objects.</p>
<p><b>3. Boom down</b></p>  <p><small>c00ic123a.eps</small></p>	<p>To lower boom, press.</p> <p>To stop movement, release.</p>	<p><b>NOTICE:</b> Do not use boom to raise or lower objects.</p>
<p><b>4. Boom retract</b></p>  <p><small>c00ic124a.eps</small></p>	<p>To retract boom, press.</p> <p>To stop movement, release.</p>	
<p><b>5. Boom extend</b></p>  <p><small>c00ic125a.eps</small></p>	<p>To extend boom, press.</p> <p>To stop movement, release.</p>	

## Wireless Control Module

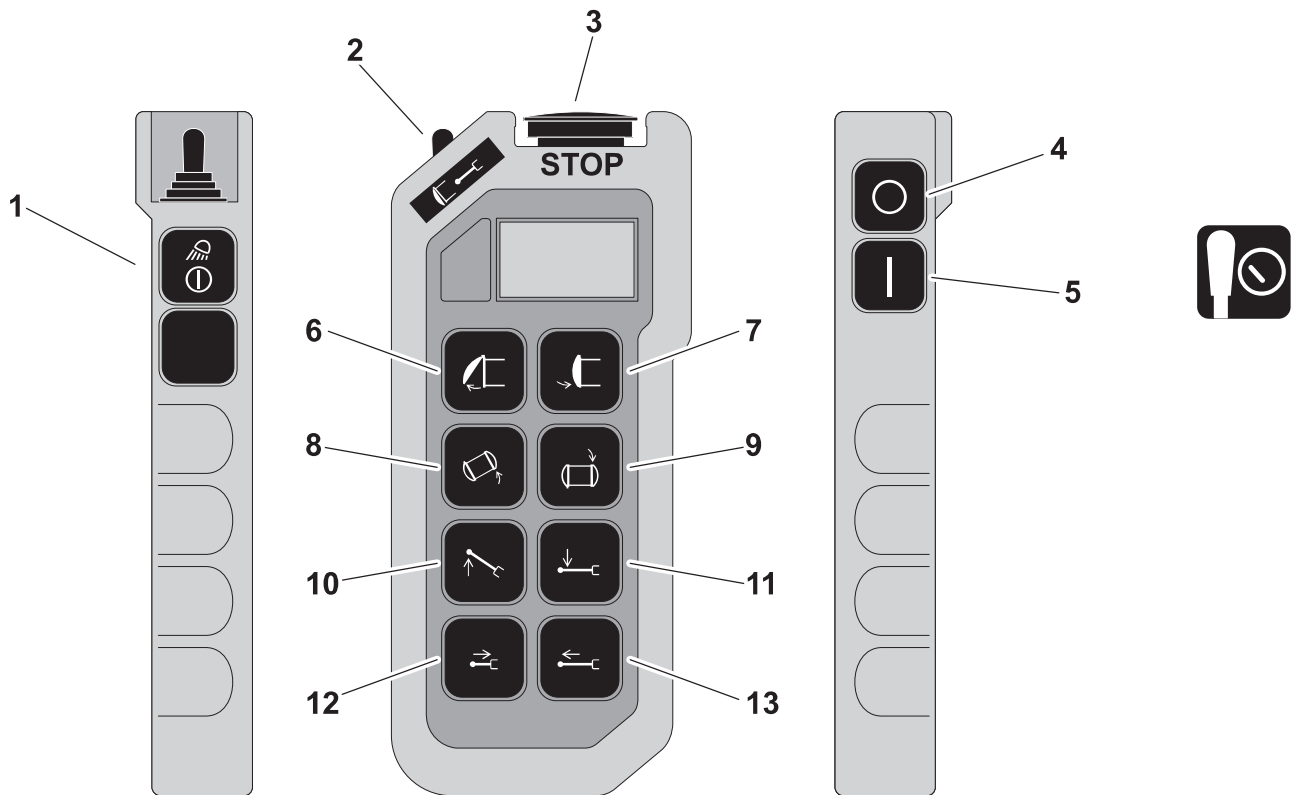

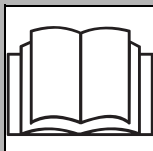

VacWirelessControl.eps



**⚠ WARNING** Read operator's manual. Know how to use all controls. Your safety is at stake. 273-475

**To help avoid injury:** Keep unit in sight when controlling tank or boom with wireless control module.

Item	Description	Notes
1. Light key	To toggle dome and option work light on and off, press.	
2. Boom/Tank selector switch	To activate tank and door controls, move to   To activate boom controls, move to 	
3. Emergency stop button	To stop engine, press.	
4. Receiver power on key	To turn on receiver module and wake up transmitter module, press.	The transmitter goes off after 20 minutes without use. The receiver does not shut off automatically.

Item	Description	Notes
5. Receiver power off key	To turn off receiver, press.	The receiver does not shut off automatically. To preserve batteries, turn off receiver when not in use.
6. Door open key	To open vacuum tank door, press.	
7. Door close key	To close vacuum tank door, press.	
8. Tank up key	To raise vacuum tank, press.	<b>IMPORTANT:</b> Do not operate tank lift while trailer is unhitched.
9. Tank down key	To lower vacuum tank, press.	
10. Boom up key	To raise boom, press.	<b>NOTICE:</b> Do not use boom to raise or lower objects.
11. Boom down key	To lower boom, press.	<b>NOTICE:</b> Do not use boom to raise or lower objects.
12. Boom retract key	To retract boom, press.	
13. Boom extend key	To extend boom, press.	

---

# Operation Overview

## Chapter Contents

<b>Planning</b> .....	<b>52</b>
<b>Setting Up at Jobsite</b> .....	<b>52</b>
<b>Vacuuming</b> .....	<b>52</b>
<b>Potholing</b> .....	<b>53</b>
<b>Leaving Jobsite</b> .....	<b>53</b>
<b>Storing Equipment</b> .....	<b>53</b>



## **Planning**

1. Gather information about jobsite (page 56).
2. Inspect jobsite (page 57).
3. Check supplies and prepare equipment (page 59).

## **Setting Up at Jobsite**

1. Prepare jobsite (page 58).
2. Position vacuum excavation unit.
3. Leave unit hitched to towing vehicle or properly stabilized.
4. Block trailer wheels.

## **Vacuuming**

1. Connect hoses (page 66).
2. Start unit (page 69).
3. Position optional vacuum boom (page 70).
4. Remove debris (page 71).
5. Disconnect hoses (page 83).
6. Drain tank (page 74).

## **Potholing**

1. Connect hoses (page 66).
2. Start unit (page 69).
3. Pothole (page 72).
4. Disconnect hoses (page 83).
5. Drain tank (page 74).

## **Leaving Jobsite**

1. Rinse unit and tools (page 83).
2. Stow tools (page 84).

## **Storing Equipment**

1. For cold weather storage, antifreeze vacuum excavation unit (page 82).
2. For long-term storage, disconnect battery disconnect switch (page 35).





---

# Prepare

## Chapter Contents

<b>Gather Information</b> . . . . .	<b>56</b>
• Arrange for Traffic Control . . . . .	.56
• Prepare for Working Near Existing Utilities . . . . .	.56
• Plan for Emergency Services . . . . .	.56
<b>Inspect Jobsite</b> . . . . .	<b>57</b>
<b>Prepare Jobsite</b> . . . . .	<b>58</b>
• Prepare Excavation Point . . . . .	.58
<b>Check Supplies and Prepare Equipment</b> . . . . .	<b>59</b>
• Assemble Accessories . . . . .	.59
• Check Supplies . . . . .	.59
• Prepare Equipment . . . . .	.60





## **Gather Information**

A successful job begins before the excavation. The first step in planning is reviewing information already available about the job and jobsite.

### **Arrange for Traffic Control**

If working near a road or other traffic area, contact local authorities about safety procedures and regulations.

### **Prepare for Working Near Existing Utilities**

If jobsite may contain electrical lines, wear protective boots and gloves meeting the following standards:

- Boots must have high tops and meet the electric hazard protection requirements of ASTM F2413 or ASTM F1117, when tested at 14,000 volts. Tuck legs of pants completely inside boots.
- Gloves must have 17,000 AC maximum use voltage, according to ASTM specification D120.

If working around higher voltage, use gloves and boots with appropriately higher ratings.

### **Plan for Emergency Services**

Have the telephone numbers for local emergency and medical facilities on hand. Check that you will have access to a telephone.

## **Inspect Jobsite**

- Follow U.S. Department of Labor regulations on excavating and trenching (Part 1926, Subpart P) and other similar regulations.
- Contact your local One-Call (811 in USA) or the One-Call referral number (888-258-0808 in USA and Canada) to have underground utilities located before digging. Also contact any utilities that do not participate in the One-Call service..
- Inspect jobsite and perimeter for evidence of underground hazards, such as:
  - “Buried utility” notices
  - Utility facilities without overhead lines
  - Gas or water meters
  - Junction boxes
  - Drop boxes
  - Light poles
  - Manhole covers
  - Sunken ground
- Mark location of all buried utilities and obstructions.



## Prepare Jobsite



**WARNING** Jobsite hazards could cause death or serious injury. Use correct equipment and work methods. Use and maintain proper safety equipment. 274-050

### To help avoid injury:

- Classify jobsite as electric if jobsite classification is in question or if the possibility of unmarked electric utilities exists.
- Expose lines by hand before digging. Cutting high voltage cable can cause electrocution.
- All vegetation near operator's station must be removed. Contact with trees, shrubs, or weeds during electrical strike could result in electrocution.

## Prepare Excavation Point

- Clear the area to be excavated. Remove rocks or branches too large for vacuum hose.
- If excavating fluids while drill string is moving, clear area of trees, shrubs, and weeds.
- Select a solid area to stand on while excavating.

## Check Supplies and Prepare Equipment

### Assemble Accessories

#### Fire Extinguisher

If required, mount a fire extinguisher near the power unit but away from possible points of ignition. The fire extinguisher should always be classified for both oil and electric fires. It should meet legal and regulatory requirements.

#### Lighting Kit

If you will need additional light, plug lighting kit into provided outlet. Contact your Ditch Witch® dealer for further information.

### Check Supplies

- water and additional hoses
- fuel
- keys
- spray lubricant
- personal protective equipment, such as hard hat and safety glasses



## **Prepare Equipment**

### **Fluid Levels**

- fuel
- hydraulic fluid
- engine coolant
- battery charge
- engine oil
- blower oil

### **Condition and Function**

- filters (air, oil, hydraulic)
- belts
- hydraulic pump
- blower
- tires
- hoses and valves
- couplers and fittings
- water tanks

---

# Transport

## Chapter Contents

<b>Lift</b> .....	<b>62</b>
• Points .....	.62
• Procedure .....	.62
<b>Haul</b> .....	<b>63</b>
• Inspect Trailer .....	.63
• Hitch Trailer .....	.64
• Unhitch Trailer .....	.64

**IMPORTANT:** These transport instructions cover the FX60 trailer-mounted version only.



## Lift

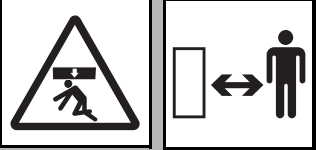

**WARNING** Crushing weight could cause death or serious injury. Stay away. 275-326

### Points

Lifting points are identified by lifting decals. Lifting at other points is unsafe and can damage machinery.

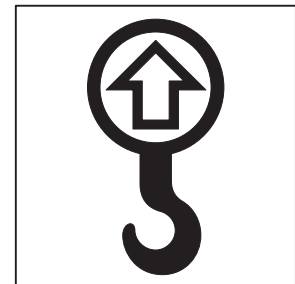

ic1319a.eps

### Procedure

#### Power Pack

Use a crane capable of supporting 3000 lb (1360 kg). Use top lift point as shown.

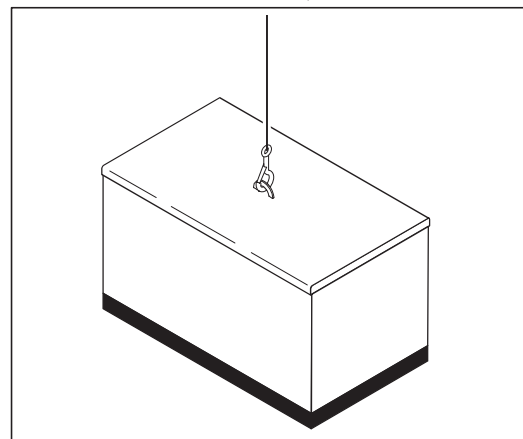

j08om002h.eps

### Tank

Use crane capable of supporting the weight shown below. Use top lift point (1) as shown. Use end lift point (2) to drain tank if machine is disabled.

800 gallon	2500 lb ( kg) kg
1200 gallon	3000 lb (1360 kg)

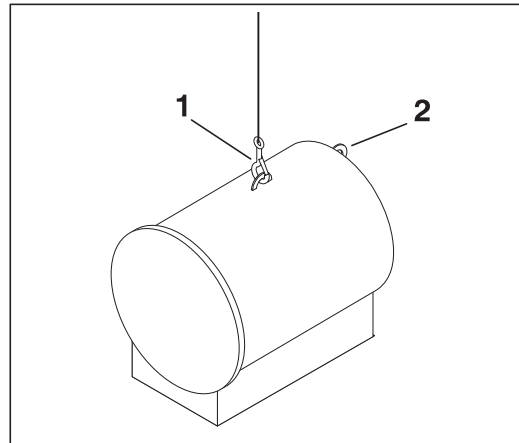

j08om004h.eps

**NOTICE:**

- Relieve pressure in tank before storing or transporting.
- Only lift empty water or spoils tanks.
- Do not lift tank by vacuum boom, if installed.

### Haul

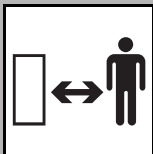

**WARNING**  
away. 275-326

Crushing weight could cause death or serious injury. Stay

**To help avoid injury:**

- Do not haul or move trailer unless tank is fully lowered and horizontal. Damage to machine or injury to personnel could occur.
- Do not haul or move trailer unless optional vacuum boom is secured by boom latch. Damage to machine or injury to personnel could occur.

### Inspect Trailer

- Check hitch for wear and cracks. Lubricate if needed.
- Check battery for 12 volt charge.
- Inspect lights for cleanliness and correct operation. Inspect reflectors and replace if needed.
- Check tire pressure. Check lug nut torque with a torque wrench.
- Ensure trailer brakes are adjusted to come on in synchronization with tow vehicle brakes.
- Check ramps (if equipped) and trailer bed for cracks.





## Hitch Trailer

1. Back tow vehicle to trailer.
2. Put manual transmission into first or reverse gear or automatic transmission into park. Turn off ignition. Set parking brake.
3. Connect trailer drawbar, lunette or coupler to tow vehicle hitch and lock in place with lock pin. If needed, adjust drawbar, lunette or coupler height (shown) to level load.
4. Connect safety chains to tow vehicle chain keepers (cross-shaped slots on bumper of tow vehicle). Attach left chain to right side of tow vehicle and vice versa to cradle hitch. Do not connect to pintle hook or hitch ball.
5. Connect breakaway switch cable to tow vehicle. Do not connect to pintle hook or hitch ball.
6. Plug trailer electrical connector into tow vehicle connector.
7. Use jack crank to raise jack base and stow.
8. Remove wheel blocks.

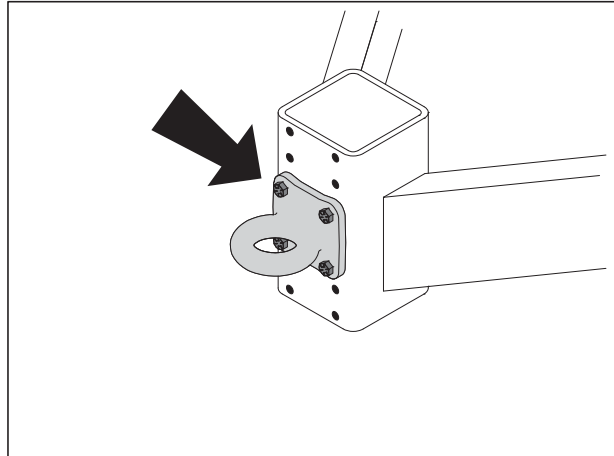

TrailerHitchAdjust\_T18.eps

## Unhitch Trailer

1. Stop tow vehicle and trailer on level ground.
2. Put manual transmission into first or reverse gear or automatic transmission into park. Turn off ignition. Set parking brake.
3. Block trailer wheels.
4. To unhitch trailer from tow vehicle, reverse "Hitch Trailer" steps.

---

# Vacuum and Pothole

## Chapter Contents

<b>Connect Hoses</b> .....	<b>66</b>
<b>Determine Tank Fill Level</b> .....	<b>67</b>
• 800-gal Vacuum Tank on T18S Trailer .....	.67
• 1200-gal Vacuum Tank on BT26 Trailer .....	.68
<b>Start Unit</b> .....	<b>69</b>
• Standard Procedure .....	.69
• Cold Start Procedure .....	.69
<b>Position Vacuum Boom</b> .....	<b>70</b>
<b>Remove Debris</b> .....	<b>71</b>
• Procedure .....	.71
<b>Pothole</b> .....	<b>72</b>
<b>Drain Tank</b> .....	<b>74</b>
<b>Open/Close Tank Door</b> .....	<b>78</b>
<b>Unload to Another Tank</b> .....	<b>76</b>



## Connect Hoses

1. Remove vacuum hoses from storage.

**If using 1200:**

- Disconnect hose end from hose catch.
- Insert hose through rollers (2).
- Pull vacuum hose reel control (1) down to unwind hose.
- Disconnect hose end (3) from hose reel.

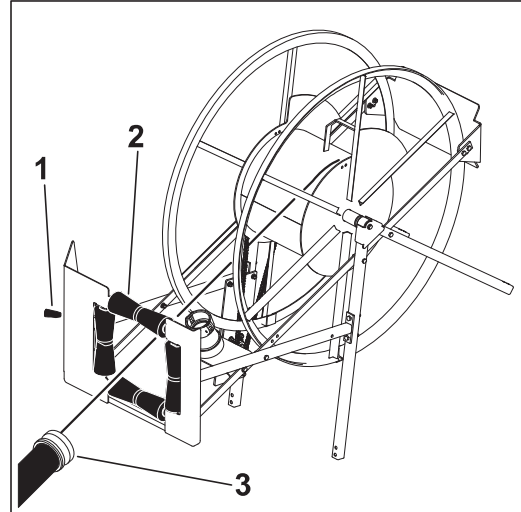

j08om005h.eps

2. If potholing, remove 2-in-1 potholing tool or basic potholing tool from storage.
3. Connect hoses. Secure all locking clamps.
4. Ensure drain/outlet valve is closed.
5. If potholing, connect water pressure hose.

2-in-1 Tool	Basic Tool
<p>A technical line drawing of a 2-in-1 potholing tool. A thick black arrow points to the top handle of the tool.</p>	<p>A technical line drawing of a basic potholing tool. A thick black arrow points to the nozzle at the end of the tool.</p>
<p>j08om006h.eps</p>	<p>j08om007h.eps</p>

## Determine Tank Fill Level (FX60 Trailer Only)

Use these reference charts to help determine how full of various materials the vacuum tank can be without overloading trailer. **Exceeding the maximum fill level will overload the trailer.**

**Never** exceed the trailer capacity. You can exceed the vacuum tank lifting capacity if you drain the tank down to the lifting capacity before lifting tank.

To use these charts, first select the appropriate table based on trailer and vacuum tank size. Next find the material being excavated. If the material being excavated is not listed, find a material with similar density. Then, determine the maximum fill level based on the amount of water in the water tank.

**IMPORTANT:** For all materials, the vacuum tank should be no more than half full when lifting the tank.

### 800-gal Vacuum Tank on T18S Trailer

Material	Maximum Vacuum Tank Fill Level			
	Water tank fill level	full (200 gal)	full (300 gal)	empty (0 gal)
wood chips (dry)	100%	100%	100%	100%
snow (dry)	100%	100%	100%	100%
water	100%	93%	100%	100%
light weight mud (8-10 lb/gal)	96%	86%	100%	100%
earth (dry, loose)	90%	81%	100%	100%
caliche	83%	74%	100%	100%
earth, loam	83%	74%	100%	100%
medium weight mud (10-12 lb/gal)	79%	70%	95%	95%
limestone (crushed)	68%	61%	82%	82%
asphalt	65%	58%	79%	79%
sand (dry)	65%	58%	78%	78%
earth (wet, excavated)	65%	58%	78%	78%
heavy weight mud (12-15 lb/gal)	64%	57%	78%	78%
gravel (dry)	63%	56%	76%	76%
shale, riprap	62%	55%	75%	75%
sand (wet)	50%	45%	61%	61%



**1200-gal Vacuum Tank on BT26 Trailer**

Material	Maximum Vacuum Tank Fill Level	
	full (500 gal)	empty (0 gal)
Water tank fill level	full (500 gal)	empty (0 gal)
wood chips (dry)	100%	100%
snow (dry)	100%	100%
water	94%	100%
light weight mud (8-10 lb/gal)	87%	100%
earth (dry, loose)	82%	100%
caliche	75%	100%
earth, loam	75%	100%
medium weight mud (10-12 lb/gal)	71%	99%
limestone (crushed)	61%	85%
asphalt	59%	81%
sand (dry)	59%	81%
earth (wet, excavated)	59%	81%
heavy weight mud (12-15 lb/gal)	58%	81%
gravel (dry)	57%	79%
shale, riprap	56%	78%
sand (wet)	48%	63%

## Start Unit

**EMERGENCY SHUTDOWN:** Turn ignition switch to STOP.

### Standard Procedure

**IMPORTANT:** If power pack is not connected to external tank control valves (for 1200 gallon), connect a -08 hose with a minimum working pressure rating of 3000 psi (207 bar) from return/tank (1) to pressure (2) connections on power pack.

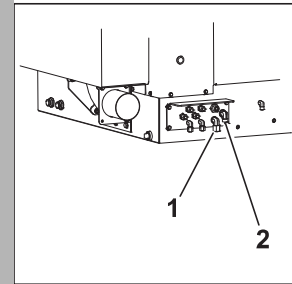

j43om009h.eps

1. Open tank inlet valve.

**NOTICE:** Avoid idling engine with inlet valve closed.

2. If equipped with reverse flow, ensure vacuum is in “vacuum” mode before starting.
3. Insert key.
4. Turn key clockwise. See page 34 for more information.
5. Run engine at low throttle for 5 minutes.



### Cold Start Procedure



**WARNING**

Fire or explosion possible. Do not use starter fluid. 273-459  
(2P), 274-206 (2P), 700-206 (2P)

1. Open tank inlet valve.

**NOTICE:** Avoid idling engine with inlet valve closed.

2. If equipped with reverse flow, ensure vacuum is in “vacuum” mode before starting.
3. Insert key.
4. Wait for glow plug indicator to go out.
5. Turn key clockwise. See page 34 for more information.
6. Run engine at low throttle for 5 minutes.

## Position Vacuum Boom

The vacuum boom is optional equipment. Contact your Ditch Witch® dealer to add this option.

### Procedure

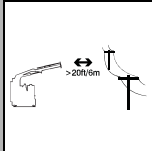
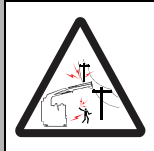

**⚠ DANGER** Do not get boom near power lines. Death or serious injury will occur. Keep required distance between boom and power lines. Use a spotter. 270-1983

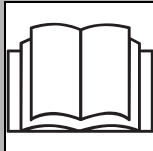

**⚠ WARNING** Read operator's manual. Know how to use all controls. Your safety is at stake. 273-475

#### To help avoid injury:

- Latch boom before tilting tank.
- Do not unlatch boom when tank is tilted up.
- If unit is parked on a slope, control boom so it does not swing freely when released.
- Do not use boom to lift or move objects. Using boom in an inappropriate way may damage equipment or injure personnel.

See "Controls" on page 31 to become familiar with the power pack controls and the boom controllers.

1. Start engine.
2. Set hydraulic function switch to "boom" position.
3. Remove vacuum hoses from storage.
4. Pull boom latch cable to release boom.
5. Use boom controller to:
  - raise boom until it clears saddle.
  - extend/retract boom to desired length.
  - raise/lower boom to desired height.
6. Rotate boom by manually swinging it left or right.

## Remove Debris

**EMERGENCY SHUTDOWN:** Turn ignition switch to STOP.

### Procedure

1. Position vacuum hose in area to be excavated.
2. Start engine.

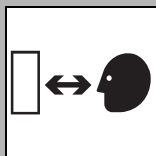

**⚠ DANGER** Vacuum can suffocate. Keep hose end away from face. 273-205



**⚠ WARNING** Fire or explosion possible. Do not vacuum flammable or combustible substances. 273-483

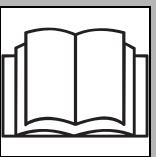

**⚠ WARNING** Read operator's manual. Know how to use all controls. Your safety is at stake. 273-475

**To help avoid injury:** Do not excavate hazardous or toxic materials. Unit is designed to excavate only soil cuttings, drilling fluids, and other non-toxic waste.

3. Open inlet valve if necessary to begin excavation.
4. Use sight glasses to monitor debris level in tank. Vacuum will shut off when tank is full but always heed trailer and tank lifting capacities as indicated on page 67. Engine will remain running.







# Pothole

**EMERGENCY SHUTDOWN:** Turn ignition switch to STOP.

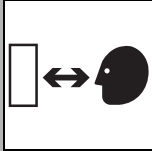
1. Start engine.

**⚠ DANGER** Vacuum can suffocate. Keep hose end away from face. 273-205





**⚠ WARNING** Fire or explosion possible. Do not vacuum flammable or combustible substances. 273-483

2. Open water tank valve.

**NOTICE:** Avoid idling engine with inlet valve closed.

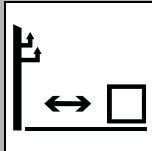
3. Move water pump switch to on.
4. Open inlet valve.
5. Position tool over area to be excavated and begin pothole.

**⚠ DANGER** Electric shock will cause death or serious injury. Stay away.

**To help avoid injury:** Do not direct water lance at overhead lines. Water conducts electricity.

2-in-1 Tool	Basic Tool
<ul style="list-style-type: none"> <li>• Squeeze water pressure lever to start water pressure.</li> <li>• Work pressurized water in a rocking or circular motion to loosen and excavate soil until hole is at the desired diameter and depth.</li> </ul>	<ul style="list-style-type: none"> <li>• First use water lance to loosen soil.</li> <li>• Work tool in a rocking or circular motion to excavate soil.</li> <li>• Use water lance and tool alternately until hole is at the desired diameter and depth.</li> </ul>

6. Adjust water pressure as needed to match soil conditions and/or material of utility being exposed.



**⚠ WARNING** Jobsite hazards could cause death or serious injury. Use correct equipment and work methods. Use and maintain proper safety equipment. 274-050

**To help avoid injury:** Test water pressure on a sample of the utility line material to be exposed. Adjust pressure until no damage occurs to the material. High pressure water can cut utility lines.

7. Ensure that water sprays from nozzle in a fan pattern. If it does not, nozzle may be clogged and pump will not function properly. Clean or replace nozzle as necessary.
8. When freshwater tank is empty, stop operation and turn water pump switch to off.

**NOTICE:** Do **not** continue to operate with freshwater tank empty. Running water pump with no water will damage pump.



## Drain Tank

**EMERGENCY SHUTDOWN:** Turn ignition switch to STOP.

1. Ensure that unit is hitched to vehicle. See "Hitch Trailer" on page 64.
2. Haul unit to approved dumping area.

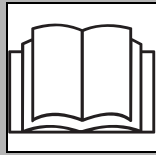

**WARNING** Read operator's manual. Know how to use all controls. Your safety is at stake. 273-475

**To help avoid injury:**

- Do **not** unhitch unit from tow vehicle before or during dumping. A freestanding unit can become unstable when tilting tank.
- Do not unlatch door with tank tilted up.
- Do not unlatch vacuum boom (optional) with tank tilted up.

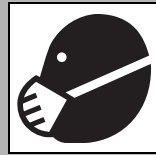

**CAUTION** Use breathing protection when exposed to silica dust. 270-4952

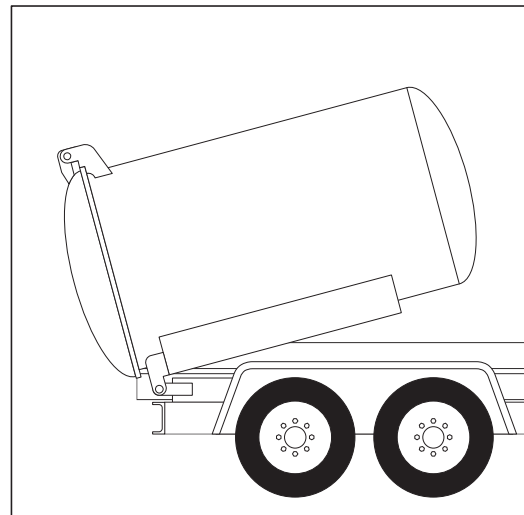

**NOTICE:** Do not drive with tank or door raised.

3. Open drain/outlet valve and inlet valve.
4. Allow tank to drain in the horizontal position until tank is approximately half drained. Monitor sight glasses.
5. When tank is half drained, start engine and run at low idle.
6. Tilt tank up to help flush solids from tank.
7. Lower tank to the full horizontal position.
8. Close drain/outlet valve and inlet valve.

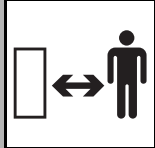

j08om056h.eps

9. If further draining is necessary, open tank door. See "Open/Close Tank Door" on page 78.



**WARNING** Crushing weight could cause death or serious injury. Stay away. 275-326

**To help avoid injury:** Use tools (provided with unit) if unit must be serviced with tank door up.

10. Tilt tank up. Allow tank to drain completely.  
11. Connect water pressure hose to water lance.  
12. Turn water pump switch on. Adjust water pressure.  
13. Use water lance to thoroughly rinse inside of tank and around door seal.



**DANGER** 273-200

Confined space will cause suffocation. Use proper procedures for entering or stay away.

**To help avoid injury:** Enter tank only if necessary. Follow U.S. Department of Labor guidelines for entering confined spaces.

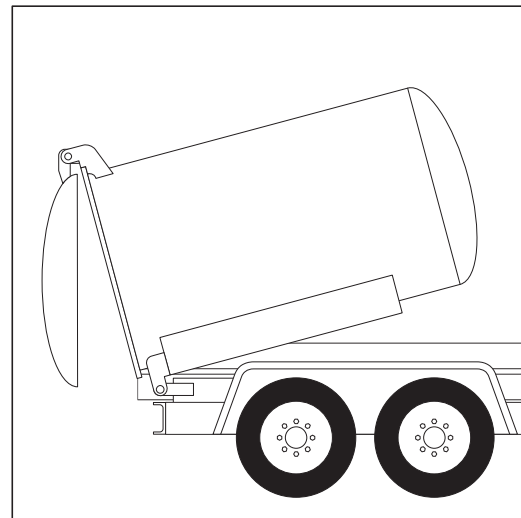

j08om057h.eps



14. Return tank to the fully lowered horizontal position.  
15. Close tank door. See "Open/Close Tank Door" on page 78.

## Unload to Another Tank

Optional reverse flow mode can be used to transfer vacuumed material to another tank or disposal site.

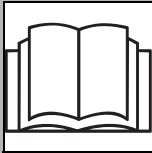

**WARNING** Read operator's manual. Know how to use all controls.  
Your safety is at stake. 273-475

### To help avoid injury:

- Keep unit in "vacuum" mode unless pressure is needed.
- Restrain hose prior to pressurization. Unrestrained hose may cause property damage, injury or death.
- Do not open fitting cams or valves when tank is pressurized. Flying debris, plugs and doors can cause injury or death.
- Do not open tank door while tank is pressurized.
- Do not use pressure to clear clogs in vacuum hose.

**IMPORTANT:** Check relief valves as shown before each use.

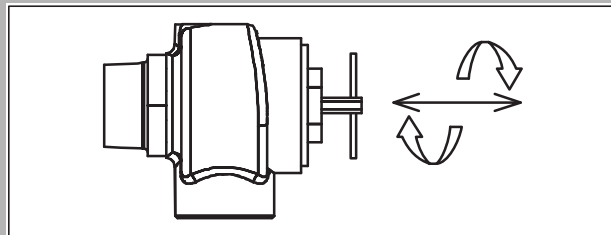

j33om059h.eps

1. Throttle down completely and turn off engine. Securely connect transfer hose to FX tank. Ensure drain/outlet valve on FX tank is closed.
2. Securely connect other end of transfer hose to offboard tank. Ensure inlet valve on offboard tank is closed and tank is vented.
3. Open FX tank drain/outlet valve. Material will flow into transfer hose.

4. Open offboard tank inlet valve. Move valve handle counterclockwise to engage "reverse flow" mode and start engine. Material will flow into offboard tank.
5. Increase throttle as desired to transfer material.
6. When transfer is complete, throttle down completely and turn off engine. Close FX tank drain/outlet valve.
7. Close offboard tank inlet valve and disconnect hose from offboard tank inlet valve.
8. Move handle clockwise to "vacuum" mode and turn on engine.
9. Open FX tank drain/outlet valve. Material will empty from transfer hose.
10. Close FX tank drain/outlet valve, throttle down and turn off engine.
11. Disconnect transfer hose from FX tank.



## Open/Close Tank Door

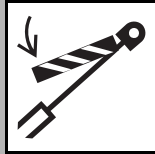

**WARNING**

Crushing weight. Place cylinder lock on extended cylinder and secure. 273-231

**To help avoid injury:** Do not raise tank with door held closed only by vacuum. Door may suddenly open and possibly injure someone.

**NOTICE:** Do not drive with tank or door raised.

**IMPORTANT:** Depressurize tank before emptying cyclonic canister, cleaning filter, clearing hoses or opening any doors.

### 800 Tank:

#### Open

1. If tank is tilted, lower tank fully before opening door.
2. Open tank inlet valve.
3. Set hydraulic function switch to door position.
4. Press OPEN on tank controller.

#### Close

1. Press CLOSE on tank controller until the linkage on both sides of the tank is fully collapsed.
2. Close tank inlet valve.

## 1200 Tank:

### Open

1. Push door seal control to SEAL.
2. Turn tank door lock counterclockwise.
3. Pull door seal control to RELEASE.
4. Turn door handle to DISENGAGE and pull out.
5. Push door lift control to OPEN.
6. Ensure door lift latch (1) engages properly. Door lift latch (1) should be fully seated on pin (2).

**NOTICE:** If door latch is not fully seated on pin, door will close and possibly injure someone.

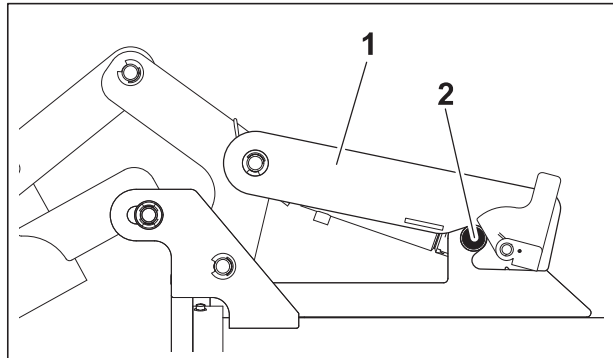

### Close

1. Fully open door to disengage door lift latch (1) from pin (2). Latch cover (3) must be down for tank door to close.
2. Pull door lift control to CLOSE.
3. Turn door handle to DISENGAGE, push in and turn to ENGAGE.
4. Push door seal control to SEAL.
5. Turn tank door lock clockwise until it stops to lock.
6. Pull door seal control to RELEASE.

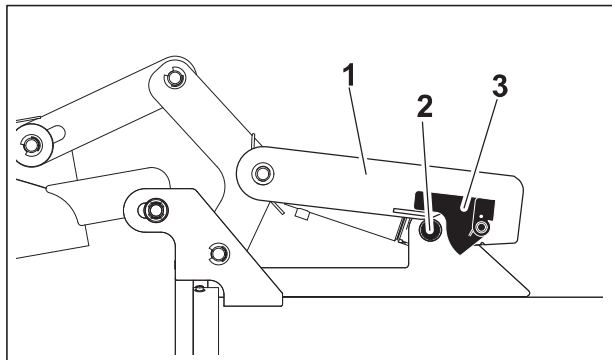





---

# Complete the Job



## Chapter Contents

<b>Antifreeze Fluid Excavation Unit</b> . . . . .	<b>82</b>
• Add Antifreeze . . . . .	.82
• Reclaim Antifreeze . . . . .	.82
<b>Rinse Equipment</b> . . . . .	<b>83</b>
<b>Disconnect</b> . . . . .	<b>83</b>
<b>Stow Tools</b> . . . . .	<b>84</b>

## **Antifreeze Fluid Excavation Unit**

### **Add Antifreeze**

Follow these steps for overnight or long-term storage of unit during cold weather.

1. Fill antifreeze tank with a propylene-glycol based antifreeze.
2. Ensure that water tank valve is closed.
3. Open antifreeze tank valve.
4. Connect water pressure hose to water lance.
5. Start engine.
6. Move water pump switch to on.
7. Squeeze water lance handle and run until antifreeze runs through the water lance.
8. Move water pump switch to off.
9. Close antifreeze tank supply valve.
10. Turn ignition switch to off.
11. Drain water tank completely.

### **Reclaim Antifreeze**

1. Turn water pressure down.
2. Move water pump switch to on.
3. Put end of water lance in antifreeze tank.
4. Squeeze water lance handle and run until water comes out of lance.
5. Move water pump switch to off.

## Rinse Equipment



Spray water onto equipment to remove dirt and mud. Use water lance. Thoroughly rinse inside of tank and around door seal.

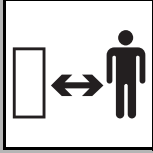

**⚠ DANGER** Confined space will cause suffocation. Use proper procedures for entering or stay away. 273-200

**To help avoid injury:** Enter tank only if necessary. Follow U.S. Department of Labor guidelines for entering confined spaces.

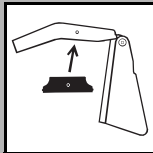

**⚠ WARNING** Crushing weight can cause death or serious injury. Pin door lock on linkage before servicing. 270-5216

**NOTICE:** Do not spray water onto operator's console. Electrical components could be damaged. Wipe down instead.

## Disconnect

Disconnect and store the following hoses and cables (if used):

- vacuum hoses

**If using 1200:**

- Connect hose end (2) to hose reel.
- Push vacuum hose reel control (1) up to wind hose.

**IMPORTANT:** Ensure control returns to neutral when released. If it doesn't, have it repaired.

- Connect hose end to hose catch.
- water pressure hose

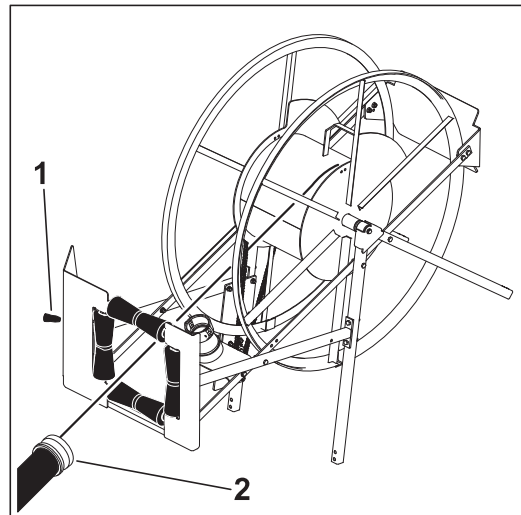

j08om075h.eps

## Stow Tools

Make sure optional vacuum boom, potholing tools, water lance, and other tools are properly stowed.

**If using 1200**, failure to stow tools as indicated could result in damage to water tank.

1. 2-in-1 potholing tool
2. Basic potholing tool
3. Water lance

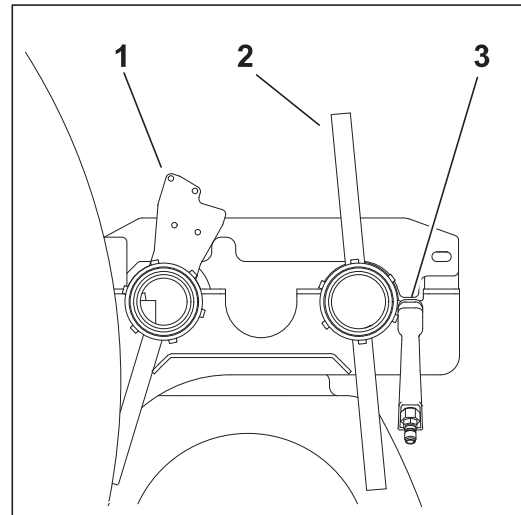

j08om008h.eps

---

# Service



## Chapter Contents

Precautions .....	86
Recommended Lubricants/Service Key .....	88
Each Use .....	91
10 Hour .....	93
25 Hour .....	104
50 Hour .....	105
100 Hour .....	109
250 Hour .....	111
500 Hour .....	112
1000 Hour .....	113
2000 Hour .....	114
As Needed .....	115
200 Mile .....	125
3000 Mile .....	125
10,000 Mile .....	126
12,000 Mile .....	127

## Service Precautions

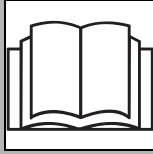

**WARNING** Read operator's manual. Know how to use all controls. Your safety is at stake. 273-475

### To help avoid injury:

- Unless otherwise instructed, all service should be performed with engine off.

Refer to engine manufacturer's manual for engine maintenance instructions.

**IMPORTANT:** Service illustrations show unit configured with 1200-gal (4542-L) tank unless indicated otherwise.

## Working Under Raised Debris Tank

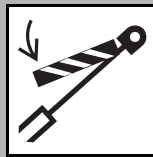

**WARNING** Crushing weight. Place cylinder lock on extended cylinder and secure. 273-231

### If using 800:

1. Raise vacuum tank.
2. Remove cylinder lockout tool and place over extended cylinder rod.
3. Lower vacuum tank until load is supported by cylinder lockout tool.

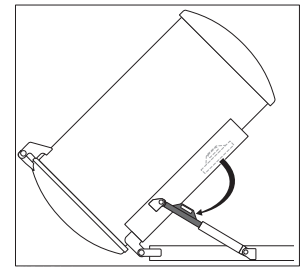

800

### If using 1200:

1. Raise vacuum tank.
2. Pull spring-loaded pin and rotate tank support leg down until pin clicks into hole.
3. Lower vacuum tank until load is supported by tank support leg.

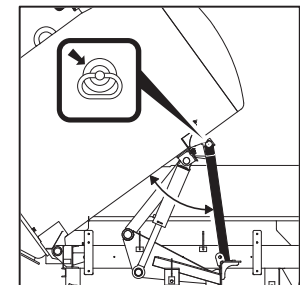

om0657h.eps

1200

## Working Under Raised Tank Door

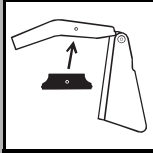

**WARNING** Crushing weight can cause death or serious injury. Pin door lock on linkage before servicing. 270-5216



### If using 800:

1. Locate door lock tools in tool storage area and bring to rear of tank.
2. Raise tank door completely.
3. Pin door lock tools into place as shown.
4. Lower tank lid until load is supported by door lock tools.

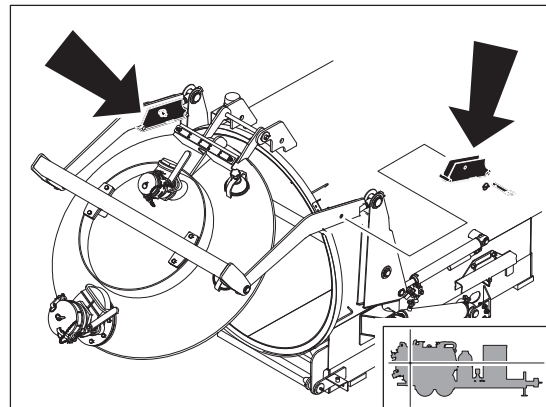

j35om074h.eps

## Welding Precaution

**NOTICE:** Welding can damage electronics.













- Disconnect battery to prevent damage to battery. Do not turn off battery disconnect switch with engine running, or alternator and other electronic devices may be damaged.
- Connect welder ground clamp close to welding point and make sure no electronic components are in the ground path.
- Always disconnect the Engine Control Unit ground connection from the frame, harness connections to the ECU, and other electronic components prior to welding on machine or attachments.

## Washing Precaution

**NOTICE:** Water can damage electronics. When cleaning equipment, do not spray electrical components with water.



## Recommended Lubricants/Service Key

Item	Description		
 DEO	Diesel engine oil meeting or exceeding Deutz specification DQC III- LA.  <b>NOTICE:</b> This unit is shipped from the factory with API CJ-4 DEO meeting Deutz specification DQC II-LA. Change oil initially at 250 hours.  <ul style="list-style-type: none"> <li>• Engine must use low sulfated ash, phosphorous, and sulfur (low (SAPS) oil.</li> <li>• See viscosity chart.</li> <li>• If oils meeting only API CJ-4 or ACEA E6/E9 are used, service interval is reduced from 500 hours to 250 hours.</li> </ul>		
 DEAC	Diesel engine antifreeze/coolant meeting ASTM D6210 (fully formulated)		
 HTG	NLGI #2 premium grade, petroleum-based grease with high temperature resistance and good mechanical stability		
 NDO	SAE30 non-detergent oil		
 SGL	Synthetic gear oil, ISO 100, p/n 256-044. See blower manual for more information.		
 MPL	Multipurpose gear oil meeting API service classification GL-5 (SAE 80W90)		
 THF	Tractor hydraulic fluid, similar to Phillips 66 HG, Mobilfluid 423, Chevron Tractor Hydraulic Fluid, Texaco TDH Oil, or equivalent		
 MPG	Multipurpose grease meeting ASTM D217 and NLGI 5		
DOT	DOT 3 or 4 brake fluid		
	Check level of fluid or lubricant		Check condition
	Filter		Change, replace, adjust, service or test

Proper lubrication and maintenance protects Ditch Witch® equipment from damage and failure. Service intervals listed are for minimum requirements. In extreme conditions, service machine more frequently. Use only genuine Ditch Witch parts, filters, approved lubricants, TJC, and approved coolants to maintain warranty. Fill to capacities listed in "Specifications" on page 129.

For more information on engine lubrication and maintenance, see your engine manual.

**IMPORTANT:** Use the "Service Record" on page 147 to record all required service to your machine.

**Engine Oil Temperature Chart**

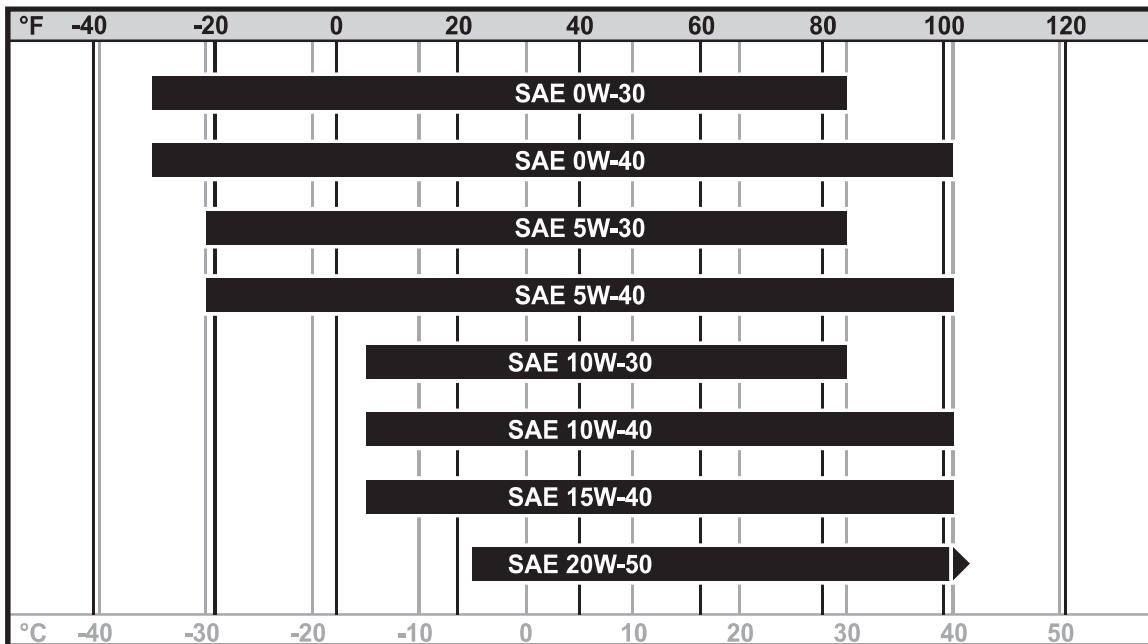

j430m045h.eps

**Temperature range anticipated before next oil change**

See engine manual for more information about oil viscosity and operation in arctic conditions.



## Approved Fuel

This engine is designed to run on diesel fuel. Use only high quality fuel meeting ASTM D975 No. 2D, EN590, or equivalent. At temperatures below 32°F (0°C) winter fuel blends are acceptable. See the engine operation manual for more information.

**NOTICE:** Use only Ultra Low Sulfur Diesel (less than 15ppm/ 15 mg/kg sulfur content) in this unit. Operating with higher sulfur content will damage the engine and aftertreatment device.

Biodiesel blends up to 5% (B5) are approved for use in this unit. The fuel used must meet the specifications for diesel fuel shown above. In certain markets, higher blends may be used if certain steps are taken. Extra attention is needed when using biodiesel, especially when operating in cold weather or storing fuel. Contact your Ditch Witch® dealer or the engine manufacturer for more information.

## Approved Coolant

This unit was filled with John Deere® Cool-Gard® coolant before shipment from factory. Add only John Deere Cool-Gard (p/n 255-006) or any fully-formulated, ethylene glycol based, low-silicate, heavy-duty diesel engine coolant meeting ASTM specification D6210.

**NOTICE:**

- Use only pre-diluted or concentrated coolant mixed with distilled water. Do not use tap water.
- Do not use water or high-silicate automotive-type coolant. This will lead to engine damage or premature engine failure.
- Do not mix heavy-duty diesel engine coolant and automotive-type coolant. This will lead to coolant breakdown and engine damage.

## Each Use

Location	Task	Notes
Trailer	Check torque of hitch bolts and verify proper hitch height	200 ft•lb (271 N•m)
	Check tire pressure and lug nut torque	
	Check lights and reflectors	



### Trailer

#### Check Torque of Hitch Bolts and Verify Proper Hitch Height

Check torque of hitch bolts. Torque varies by trailer model. Refer to "Specifications" on page 129. Verify that hitch is at the proper height to avoid adding excess load on axle and wheels.

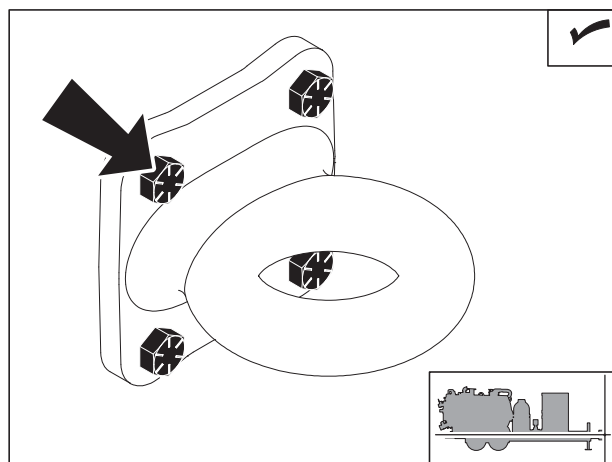

j35om004h.eps

#### Check Tire Pressure and Lug Nut Torque

Check tire pressure (2) and lug nut (1) torque. See below for correct pressure and torque.

Trailer	Pressure	Torque
T18S	125 psi (8.6 bar)	300 ft•lb (407 N•m)
T26S	110 psi (7.6 bar)	271 ft•lb (271 N•m)

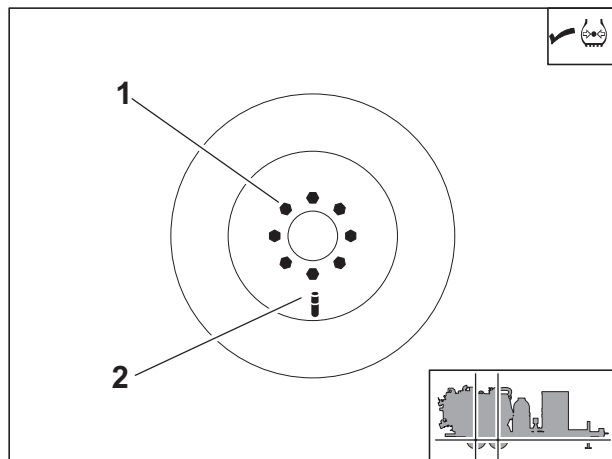

j35om009h.eps

### Check Lights and Reflectors

Check lights and reflectors for correct operation and cleanliness.

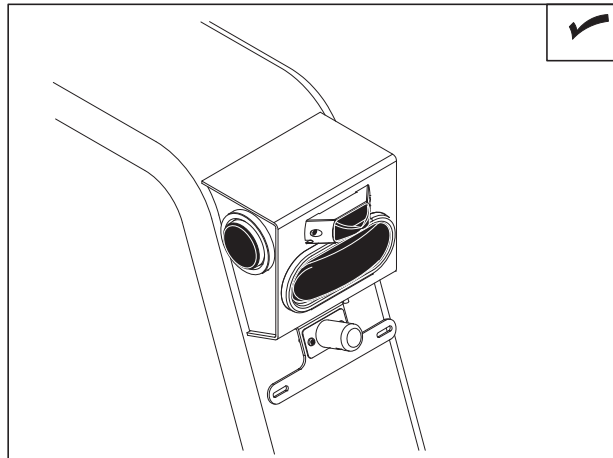

j33om013h.eps

# 10 Hour

Location	Task	Notes
<b>Vacuum System</b>	Check engine oil level	
	Drain fuel/water separator	
	Inspect belts (water pump, blower and fan)	
	Check coolant level	
	Check air filter service indicator	
	Check hydraulic fluid level	THF
	Check hydraulic hoses	
	Check blower oil level	SGL
	Check blower	
	Check water pump oil level	
	Check water pump	NDO
	Check water pump regulator	
	Clean water pump filter	
	Clean vacuum air filter	
	Drain vacuum air filter canister	
	Check spray nozzle	
Drain cyclonic separator canister		
<b>Debris Tank</b>	Check vacuum tank hoses	
	Check strobe light	
	Check vacuum tank door seals/fittings	
	Check tank deflector	



## Vacuum System

### Check Engine Oil Level

Check engine oil at dipstick (1) before operation and every 10 hours thereafter. Check with unit on level surface and at least 15 minutes after stopping engine. Add DEO at fill (2) as necessary to keep oil level at highest line on dipstick.

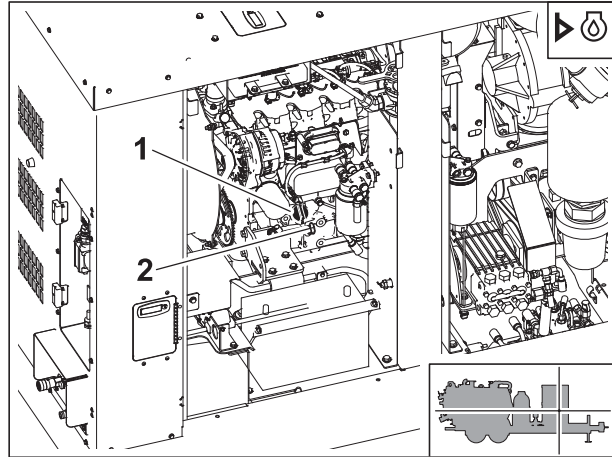

j43om010h.eps

### Drain Fuel/Water Separator

Drain water out of filter every 10 hours. To drain, place loose end of drain hose into approved container. Turn valve on bottom of filter counterclockwise 4 turns until water flows out of drain hose. When fuel comes out, turn valve clockwise to close.

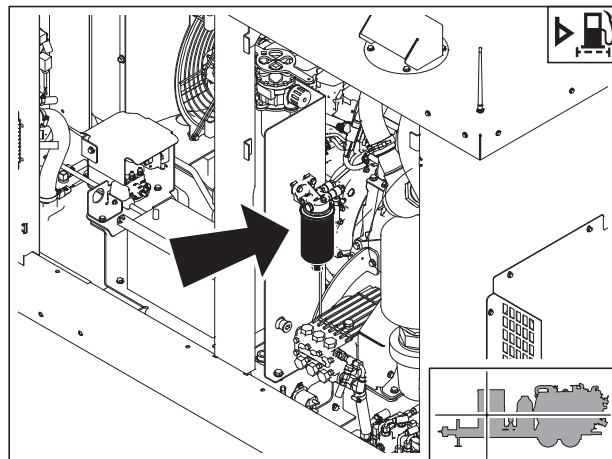

j43om011h.eps

### Inspect Belts

Check fan (2), blower (1), and water pump (3) belts every 10 hours for damage or wear.

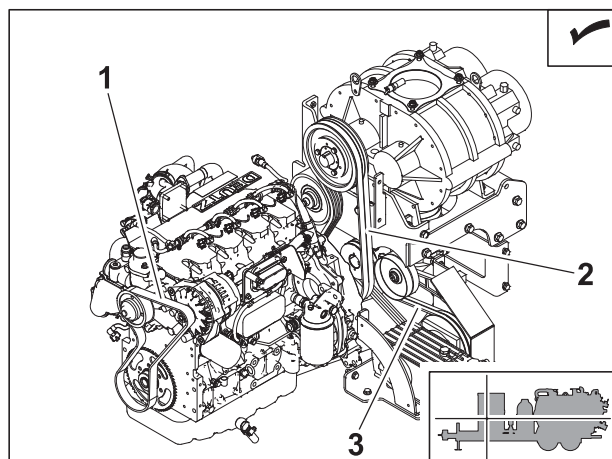

j43om012h.eps

### Check Coolant Level

Check coolant level, with engine cool, at coolant expansion tank every 10 hours. Maintain coolant level at fill line. If low, add approved coolant.

**NOTICE:**

- The use of non-approved coolant may lead to engine damage or premature engine failure and will void engine warranty.
- See "Approved Coolant" on page 90 for list of approved coolants.

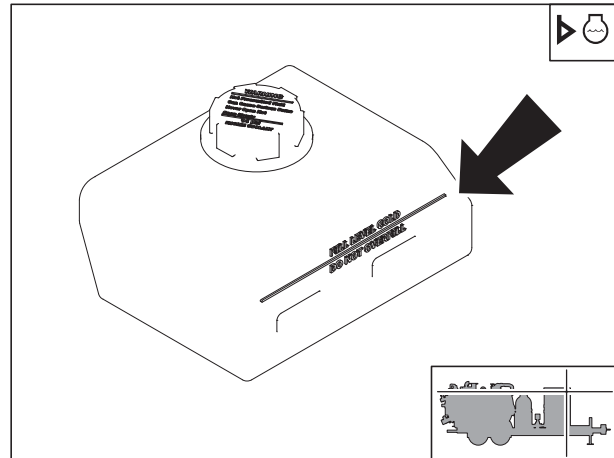

j43om013h.eps

**To fill:**

1. Slowly add coolant at expansion tank to fill line.
2. Start and operate engine for several minutes after it reaches normal operating temperature of 195°F (90°C).
3. Stop engine and allow to cool.
4. Repeat steps until coolant level is correct.

### Check Air Filter Indicator and Clean Dust Trap

Check air filter indicator (1) and inspect dust trap (2) for cracks every 10 hours. Change filter elements when indicator reaches red zone.

**NOTICE:** Only open the air filter canister when air restriction is indicated. Change the elements, do not attempt to clean them.

- Compressed air or water may damage filter elements.
- Tapping filter elements to loosen dirt may damage filter seals.

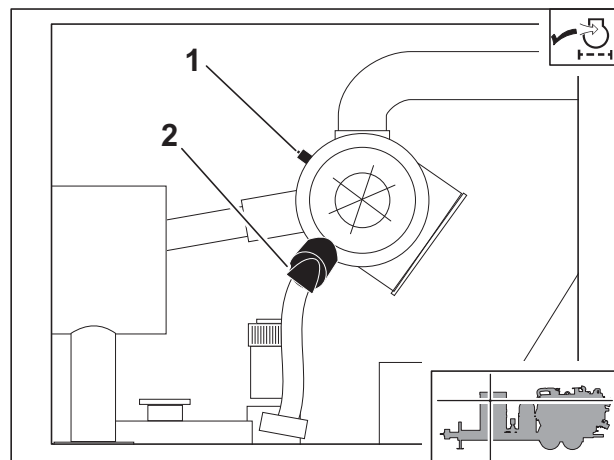

j35om035h.eps





## Check Hydraulic Fluid Level

With frame level, check oil at indicator every 10 hours. Add THF at fill as necessary. Clean dust from cap by blowing with low-pressure air.

**IMPORTANT:** Use a ladder or other means to access hydraulic fluid fill.

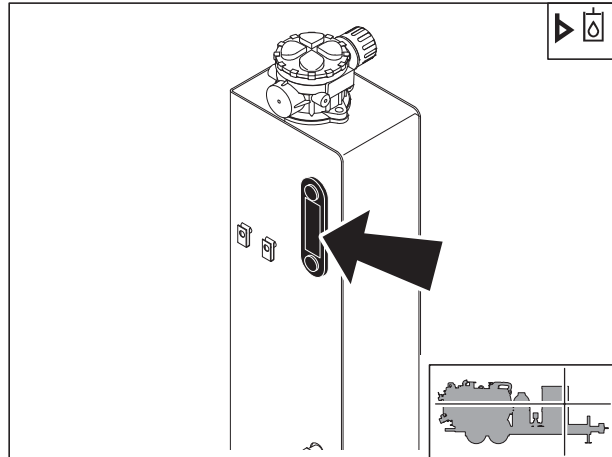

j43om014h.eps

## Check Hydraulic Hoses

Check hoses every 10 hours for wear or damage. Replace as needed.

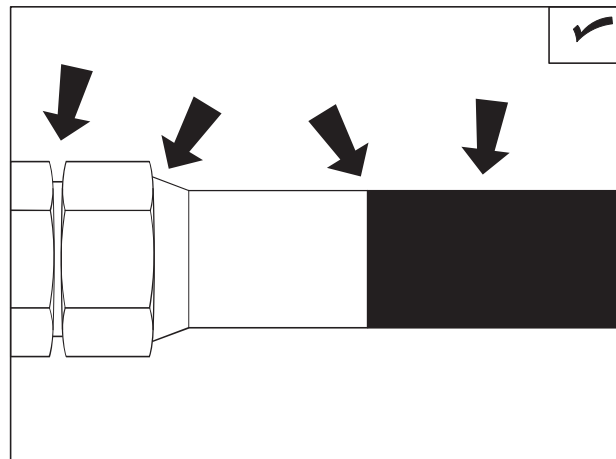

CheckHoses.eps

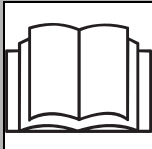

**⚠ WARNING** Pressurized fluid or air could pierce skin and cause severe injury. Refer to operator's manual for proper use. 270-6035

### To help avoid injury:

- Before disconnecting a hydraulic line, turn engine off and operate all controls to relieve pressure. Lower, block, or support any raised component with a hoist. Cover connection with heavy cloth and loosen connector nut slightly to relieve residual pressure. Catch all fluid in a container.
- Before using system, check that all connections are tight and all lines are undamaged.
- Use a piece of cardboard or wood, rather than hands, to search for leaks.
- Wear protective clothing, including gloves and eye protection.
- If you are injured, seek immediate medical attention from a doctor familiar with this type of injury.

### Check Blower Oil Level

With frame level, check blower oil at sight glass (2) every 10 hours. Add SGL at breather (1) as necessary to maintain oil level at halfway point on sight glass (2). Do not overfill.

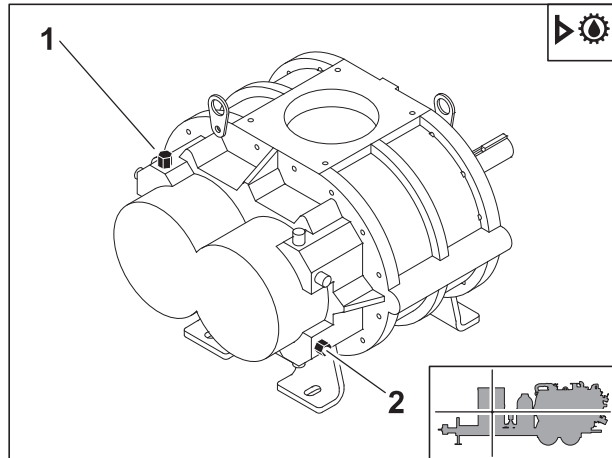

j43om015h.eps



### Check Blower

Check blower every 10 hours for unusual noise or vibration. If malfunction is detected:

1. Stop engine.
2. Consult blower repair manual.

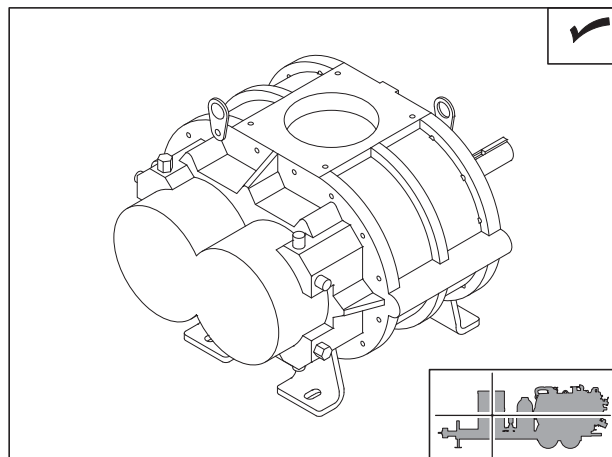

j43om016h.eps

### Check Water Pump Oil Level

With frame level, check water pump oil at dipstick every 10 hours. Oil should be at full mark on dipstick. Add NDO at fill as necessary to keep oil at full mark on dipstick.

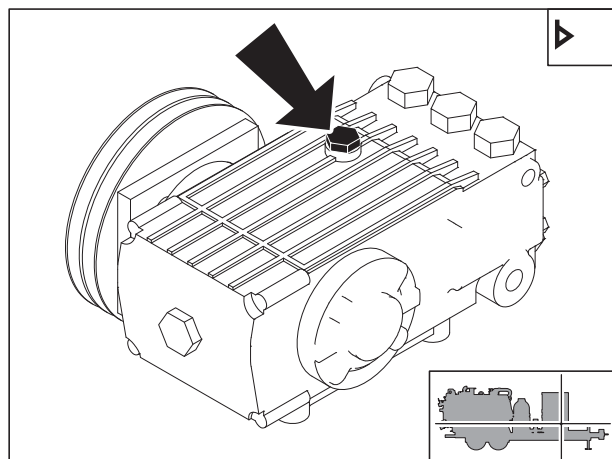

j43om017h.eps

## Check Water Pump

Check water pump unit every 10 hours for leaks, loose fittings, unusual noise or vibration. Repair if necessary.

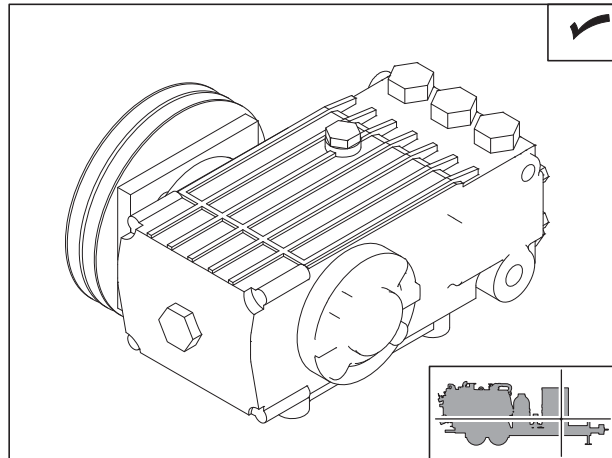

j43om018h.eps

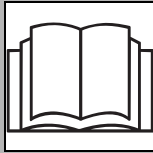

**WARNING** Pressurized fluid or air could pierce skin and cause severe injury. Refer to operator's manual for proper use. 270-6035

### To help avoid injury:

- Before using system, check that all connections are tight and all lines are undamaged.
- Use a piece of cardboard or wood, rather than hands, to search for leaks. Fluid leaks can be hard to detect.
- Wear protective clothing, including gloves and eye protection.

### Check Water Pump Regulator

Check for proper operation of regulator every 10 hours.

**To check:**

1. Start engine.
2. Connect water pressure hose to water lance.
3. Move water pressure switch to on.
4. Squeeze water lance handle. Water pump should engage.
5. Release water lance handle. Water pump should disengage.

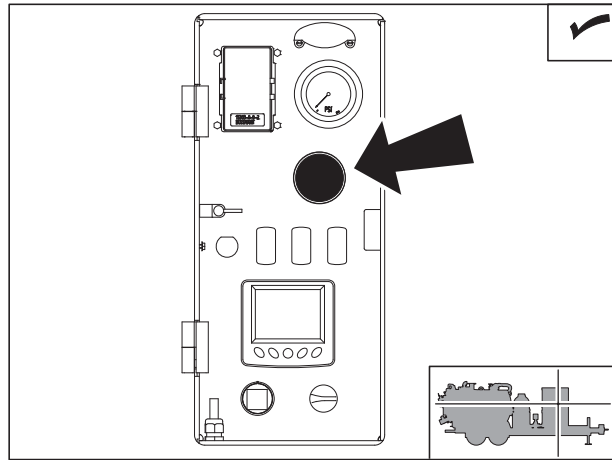

j43om019h.eps



If pump does not engage and disengage with movement of water lance handle, water pump control system is not functioning properly. See water pump manual for more information.

### Clean Water Pump Filter

Clean water pump filter every 10 hours and replace as needed.

1. Open filter housing.
2. Remove element and rinse housing thoroughly with water.
3. Inspect element for signs of collapse and for brittle or broken rubber seals on the ends of the element. Replace as needed. See page 116.
4. Replace element and close filter housing.

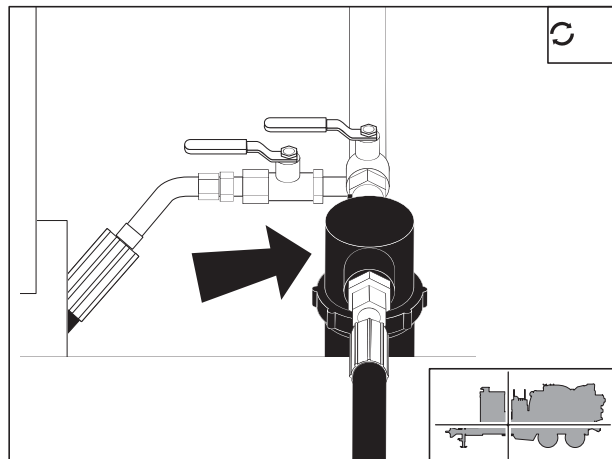

j35om040h.eps

**Clean Vacuum Air Filter**

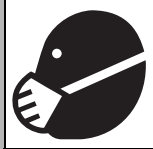

**CAUTION**

Use breathing protection when exposed to silica dust.

270-4952

Clean filter every 10 hours or as needed.

**To clean filter:**

1. Remove filter from canister.
2. Run low pressure water into inside of filter.

**NOTICE:** Do not use high pressure water to clean filter. Filter will be damaged.

3. Allow filter to dry completely before returning to canister.

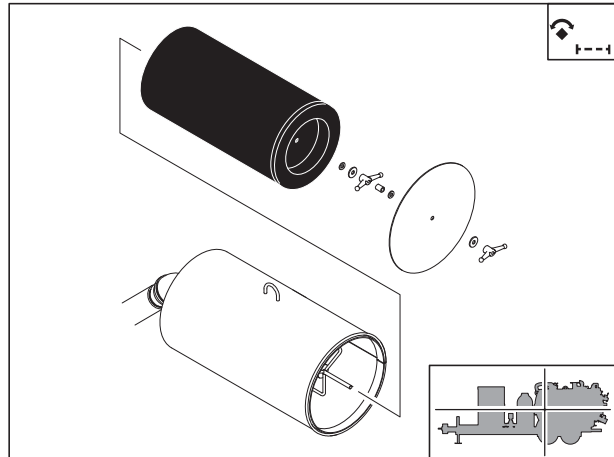

j35om013h.eps

**300/800**

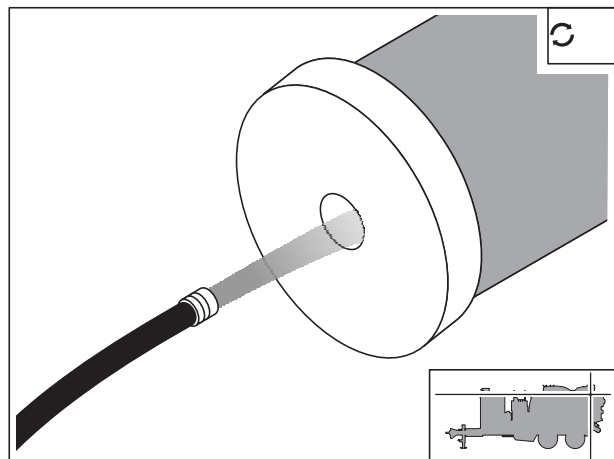

j35om068h.eps

**1200**

**Drain Vacuum Air Filter Canister (1200)**

Drain filter canister at drain (1) every 10 hours or as needed. Drain when water is visible in sight glass (2).

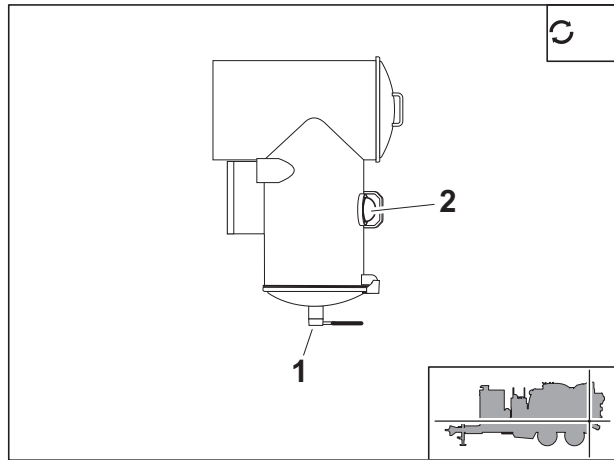

j35om042h.eps



**Check Spray Nozzle**

Check spray nozzle every 10 hours. Ensure that water sprays from nozzle in a fan pattern. Clean or replace nozzle as necessary.

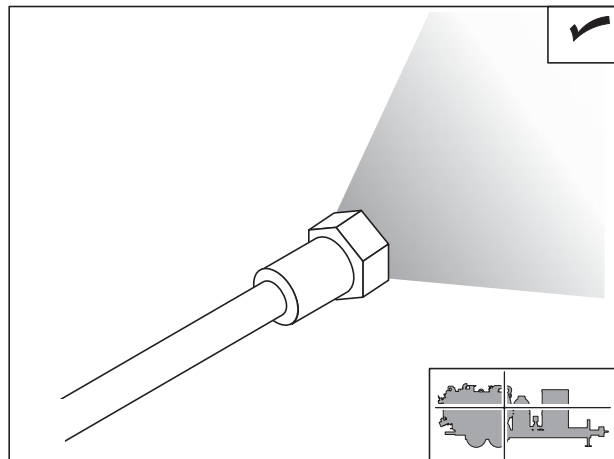

j35om015h.eps

**Drain Cyclonic Separator Canister (800)**

**IMPORTANT:** Depressurize tank before emptying cyclonic canister, cleaning filter, clearing hoses or opening any doors.

Drain canister at drain (2) every 10 hours or when water is visible in sight glass (1).

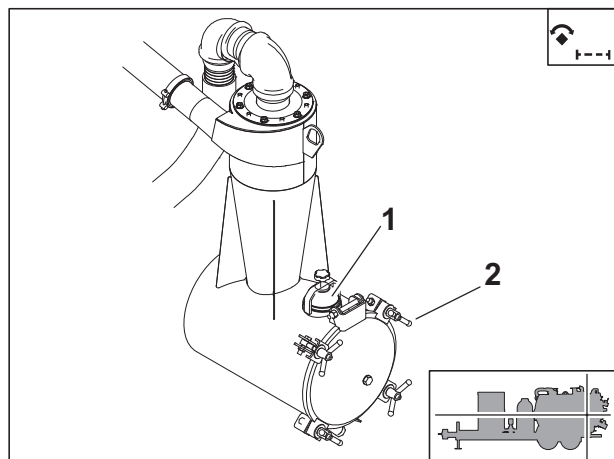

j35om014h.eps

## Debris Tank

### Check Vacuum Tank Hoses

Check hoses every 10 hours for wear or damage. Replace as needed.

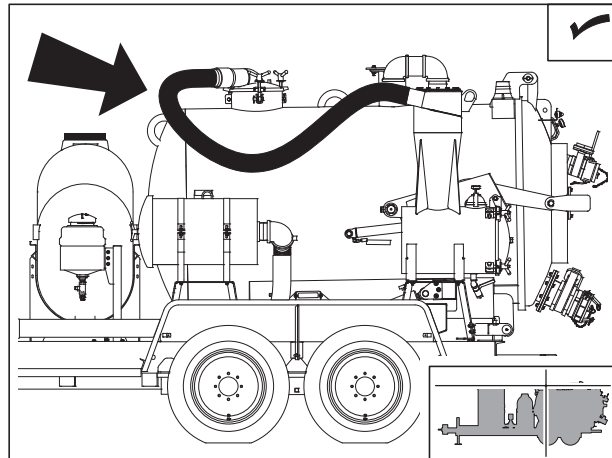

j35om041h.eps

### Check Strobe Light

Check strobe light for proper function every 10 hours. When ignition is on, strobe light should be flashing. Repair if necessary.

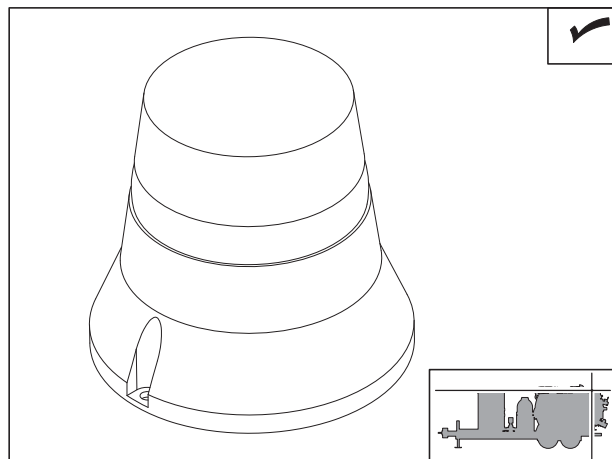

j35om016h.eps

### Check Vacuum Tank Door Seals and Fittings

Check door seal every 10 hours for wear or damage. Repair if necessary. Check for leaks and loose fittings every 10 hours. Repair or replace if necessary.

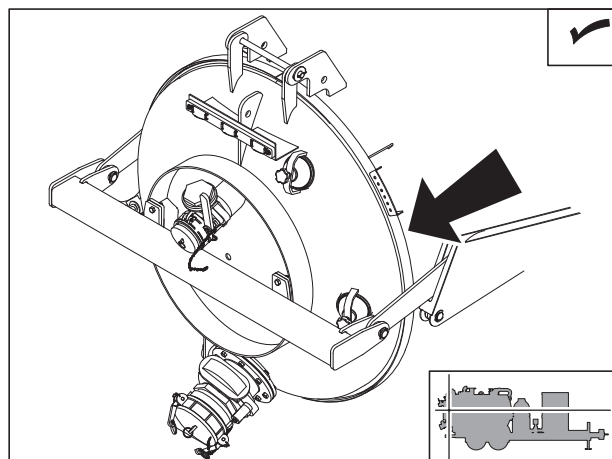

j35om017h.eps

**Check Tank Deflector**

Check tank deflector every 10 hours for buildup, wear, or damage. Clean or replace as needed.

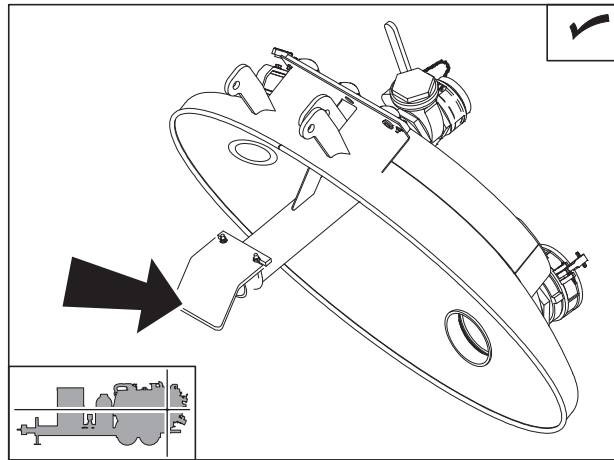

j35om022h.eps

**800**

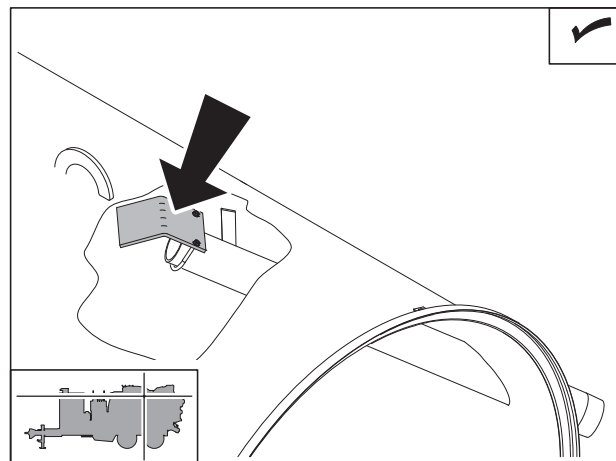

j35om050h.eps

**1200**





## 25 Hour

Location	Task	Notes
Vacuum System	Change water pump oil	Initial service, NDO

### Vacuum System

#### Change Water Pump Oil

Change oil after the first 25 hours of operation and every 100 hours thereafter. Change oil more frequently if working in dusty conditions.

- Drain at drain plug (2) while oil is warm.
- Add NDO at fill (1) until oil is at full mark on dipstick.

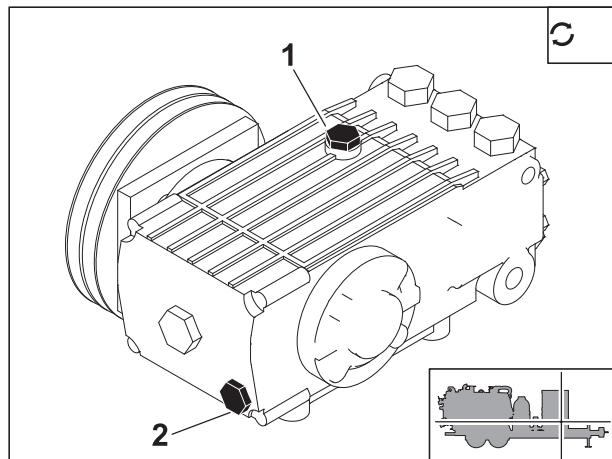

j43om020h.eps

## 50 Hour

Location	Task	Notes
<b>Vacuum System</b>	Check water pump belt tension	
	Check blower belt tension	
	Inspect cooling fan	
	Check radiator	
	Check blower relief valve	
	Check water pressure hoses	
	Check vacuum air filter and hoses	
<b>Debris Tank</b>	Lube door lock screw	1200 tank
	Lube tank pivot pins	800 tanks
<b>Vacuum Boom</b>	Lube boom pivot	Boom is optional equipment



### Vacuum System

#### Check Water Pump Belt Tension

Check belt every 10 hours for correct tension, damage or wear. Replace worn belt. Maintain tension at third mark on tensioner, as shown.

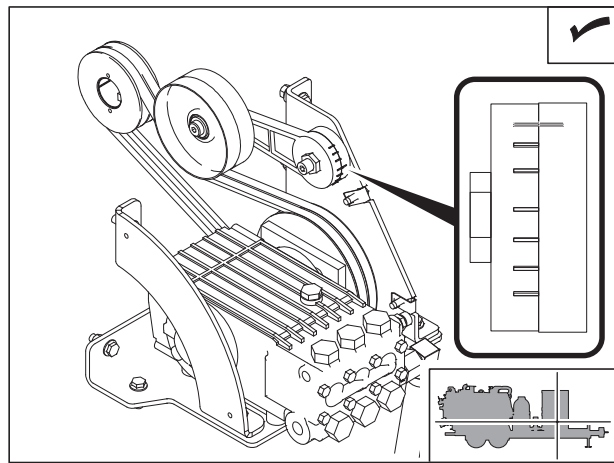

j43om021h.eps

**Check Blower Belt Tension**

Check belt every 10 hours for correct tension, damage or wear. Replace worn belt. Tighten as needed. See "Adjust Blower Belt Tension" on page 117.

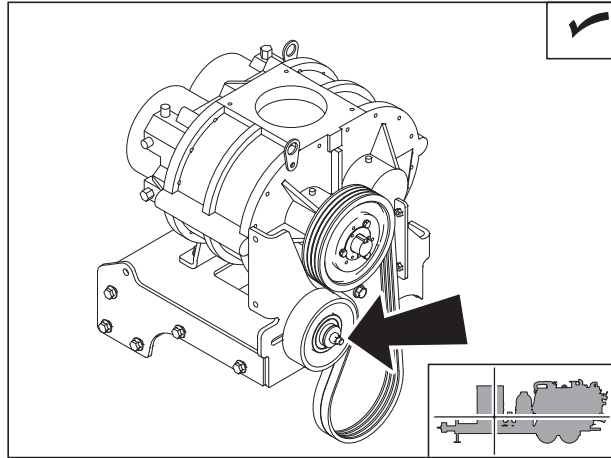

j43om023h.eps

**Inspect Cooling Fan**

Check for cracks, loose rivets, and bent or loose blades. Check mounting screws and tighten if needed.

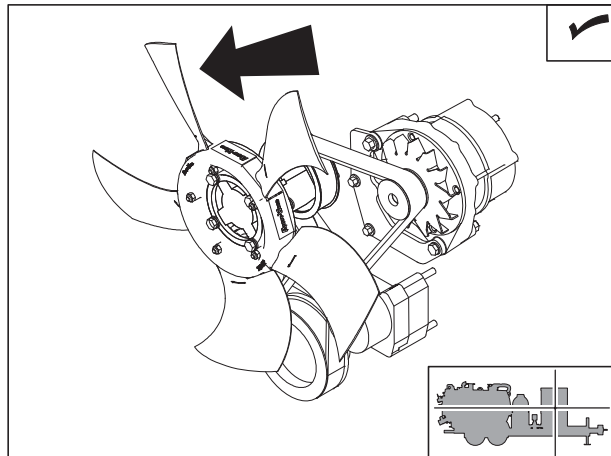

j43om025h.eps

**Check Radiator**

Check radiator for dirt, grass, and other foreign matter every 50 hours. Clean out with compressed air or spray wash if required. Be careful not to damage fins with high-pressure air or water. Check more often if operating in dusty or grassy conditions.

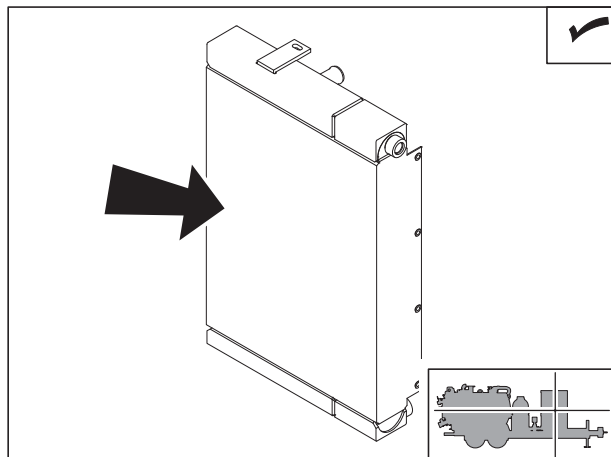

j43om026h.eps

### Check Blower Relief Valve

Check relief valve for proper operation every 50 hours.

**To check:**

1. Ensure that vacuum inlet valve and drain valve are both closed.
2. Start engine. Vacuum will start to build.
3. When vacuum goes over relief, check for suction at the bottom of the relief air filter.

If suction is not present, stop engine and check relief valve.

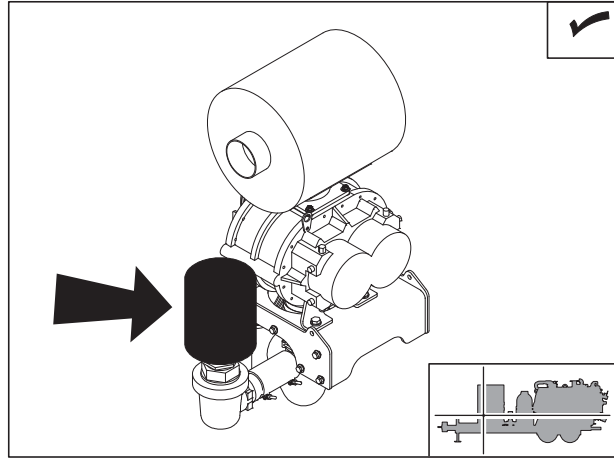

j43om044h.eps



### Check Water Pressure Hoses

Check hoses every 50 hours for wear or damage. Replace as needed.

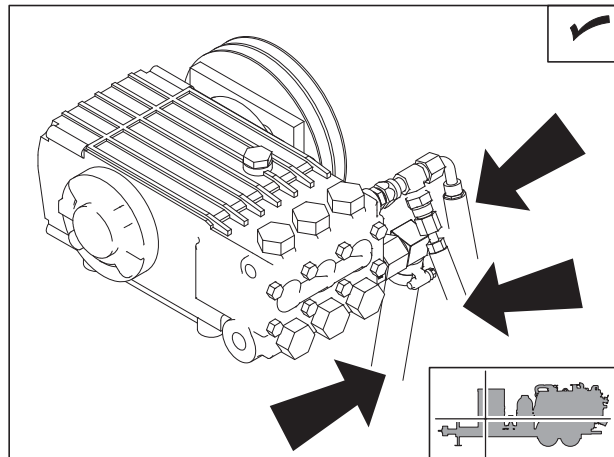

j43om027h.eps

### Check Vacuum Air Filter and Hoses

Check filter (1) and suction hose (2) every 50 hours for wear or holes. Check more often if working in dusty conditions. Clean or replace filter if necessary.

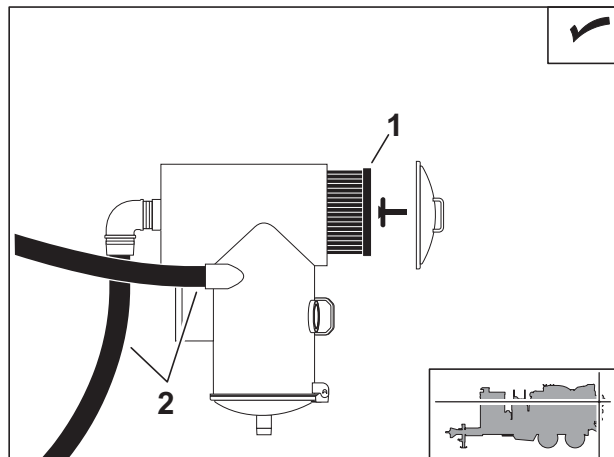

j35om047h.eps

## Debris Tank

### Lube Door Lock Screw (1200 tank)

Lube every 50 hours with MPG.

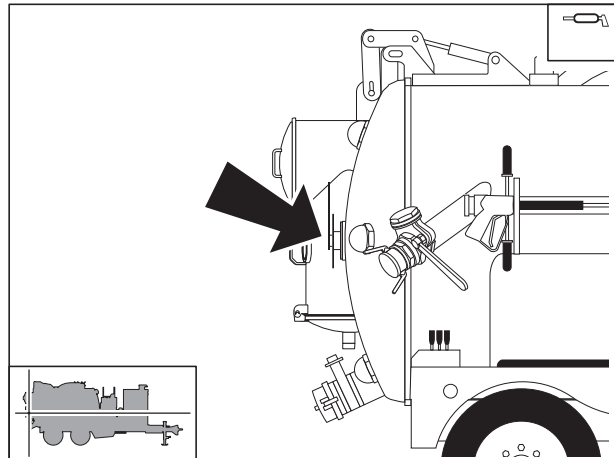

j35m048h.eps

### Lube Tank Pivot Pins (800 tanks)

Lube two pins every 50 hours with MPG.

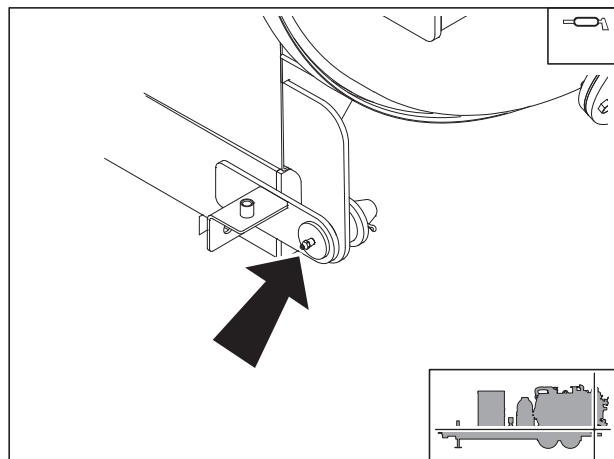

j35m020h.eps

## Vacuum Boom

### Lube Boom Pivot

Lube six zerks every 50 hours with MPG.

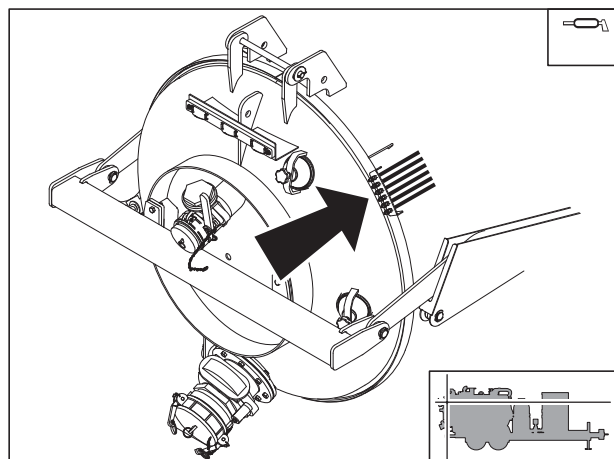

j35m021h.eps

# 100 Hour

Location	Task	Notes
<b>Vacuum System</b>	Change hydraulic fluid filter	Initial service
	Change water pump oil	NDO
	Lube blower	HTG
<b>Debris Tank</b>	Check tank deflector	
	Check tank mounting bolts	
<b>Vacuum Boom</b>	Check structure	



## Vacuum System

### Change Hydraulic Fluid Filter (Initial Service)

Use provided wrench to change hydraulic fluid filter after first 100 hours. Replace filters every 1000 hours thereafter.

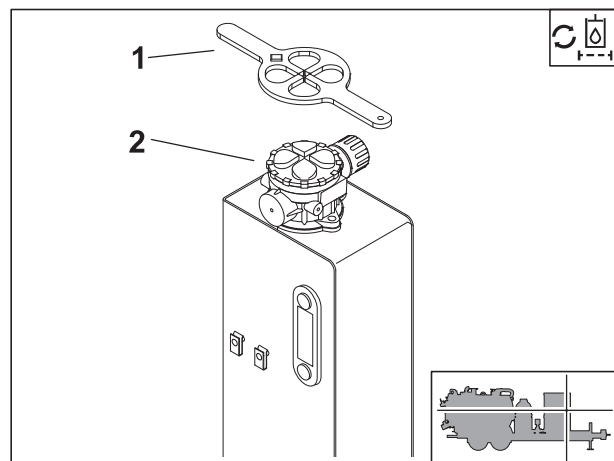

j43om028h.eps

### Change Water Pump Oil

Change oil after the first 25 hours of operation and every 100 hours thereafter. Change oil more frequently if working in dusty conditions.

- Drain at drain plug (2) while oil is warm.
- Add NDO at fill (1) until oil is at halfway mark on dipstick.

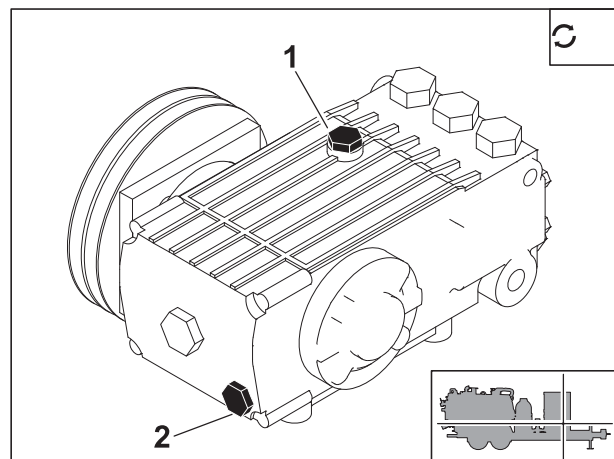

j43om020h.eps

### Lube Blower

Wipe two zerks clean and lube every 100 hours with HTG. Inject grease into zerk until clean grease comes out of relief fittings.

**NOTICE:** Do not inject grease too quickly. Drive shaft seal damage could occur.

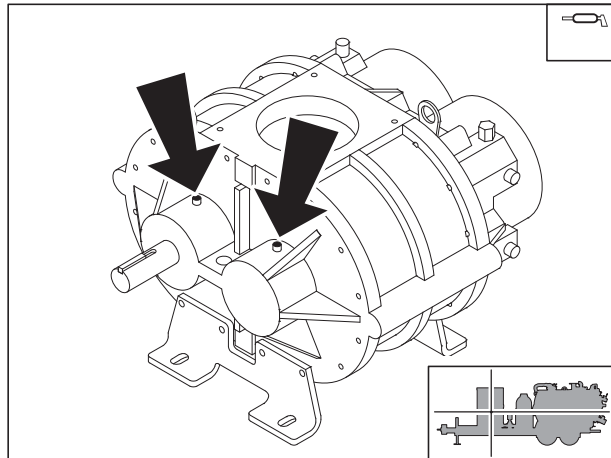

j43om032h.eps

### Debris Tank

#### Check Tank Mounting Bolts

##### 800 Tanks

Check vacuum tank mounting bolts (shown, on both sides) every 100 hours for looseness and damage. Tighten or replace as needed.

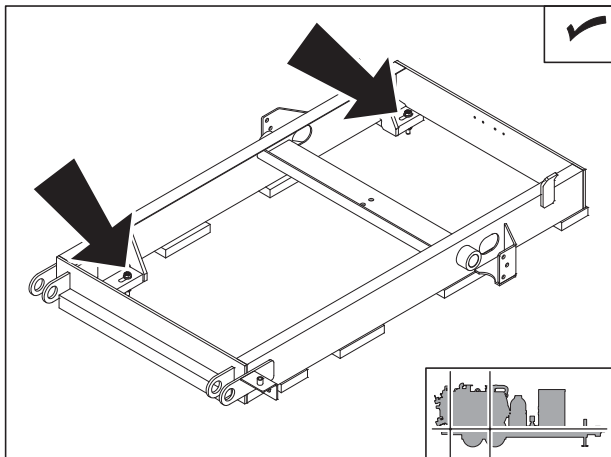

j35om071h.eps

##### 1200 Tank

Check vacuum tank mounting bolts (shown, both sides) every 100 hours for looseness and damage. Tighten or replace as needed.

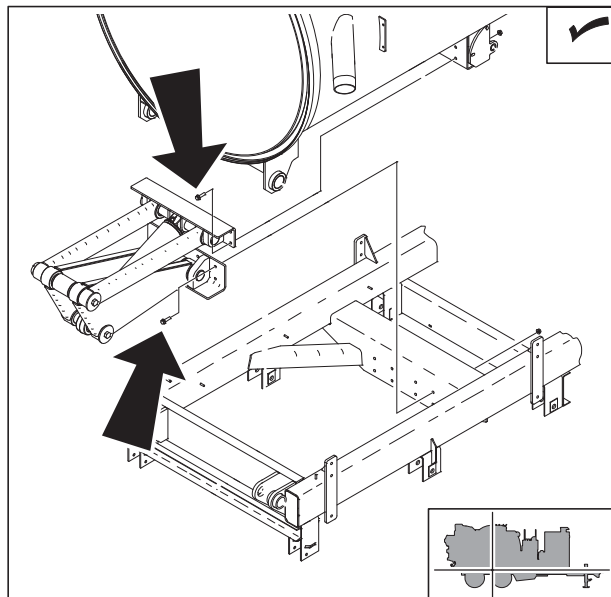

j35om071h.eps

## Vacuum Boom

### Check Structure

Check boom deflector every 100 hours. Replace as needed.



## 250 Hour

Location	Task	Notes
Vacuum System	change engine oil and filter	DEO, <b>initial</b> and if using API CJ-4 or ACEA E6/E9 oil
	Inspect air intake system	

## Vacuum System

### Change Engine Oil and Filter

Change oil and filter after 250 hours and every 250 hours if using oil meeting API CJ-4 or ACEA E6/E9. See page 88 for more information about DEO specifications.

1. Drain crankcase through drain valve (1) while oil is warm.
2. Replace filter (2) each time oil is changed.
3. Add 8.5 qt (8 L) of DEO at fill neck (4).
4. Verify correct oil level at dipstick (3).

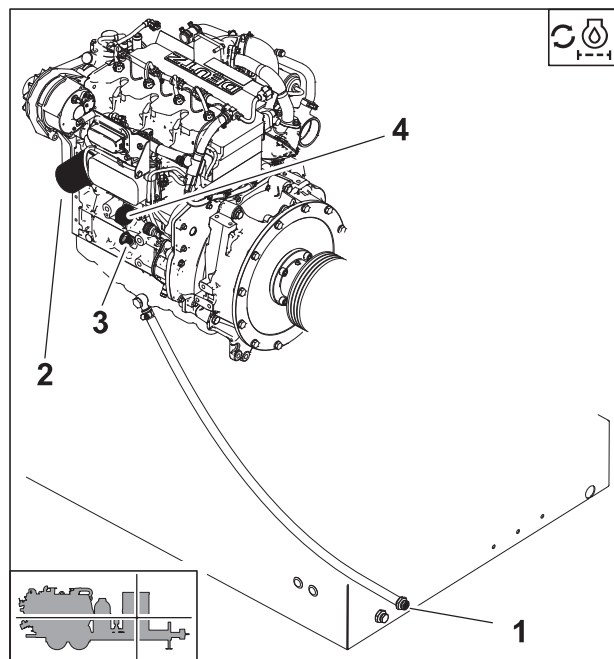

j43om030h.eps



**Inspect Air Intake System**

Inspect intake piping for cracked hoses, loose clamps, or punctures. Tighten or replace parts as necessary.

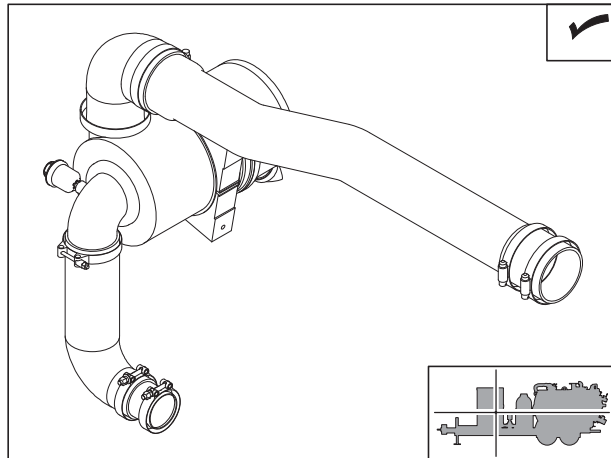

j43om029h.eps

**500 Hour**

Location	Task	Notes
Vacuum System	Change engine oil and filter	DEO; ONLY if using DQC III-LA oil
	Change fuel filters and clean filter screen	

**Vacuum System**

**Change Engine Oil and Filter**

Change oil and filter every 500 hours ONLY if using oil meeting Deutz DQC III- LA. See page 88 for more information about DEO specifications.

1. Drain crankcase through drain valve (1) while oil is warm.
2. Replace filter (2) each time oil is changed.
3. Add 8.5 qt (8 L) of DEO at fill neck (4).
4. Verify correct oil level at dipstick (3).

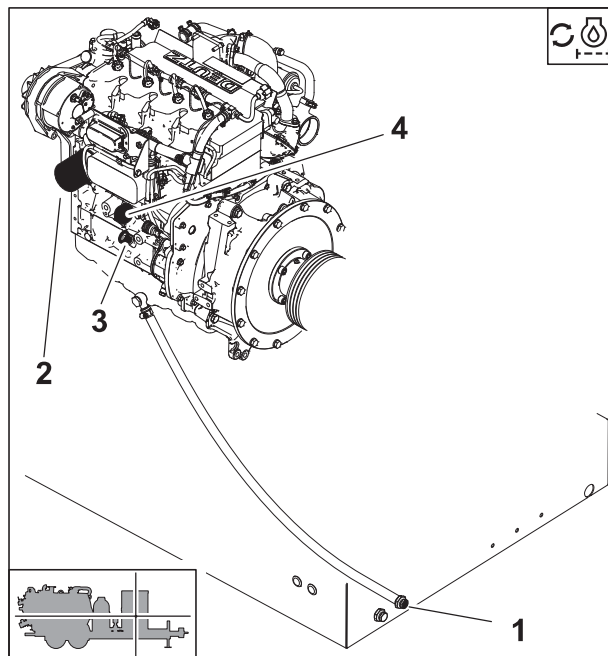

j43om030h.eps

**Change Fuel Filters**

Replace primary and secondary fuel filters and clean filter screen every 500 hours for normal service. See parts manual or contact your Ditch Witch® dealer for correct replacement filter.

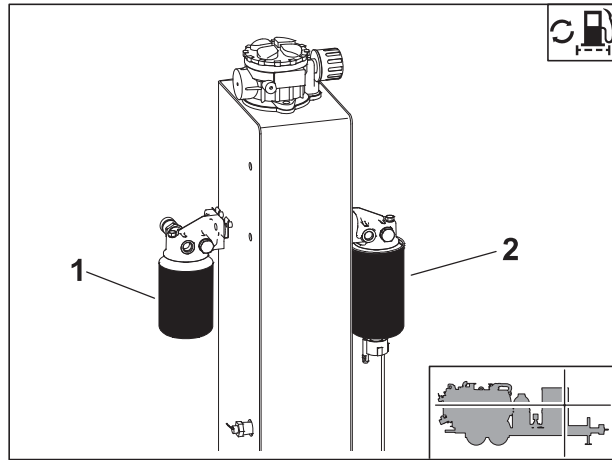

j43om031h.eps



**1000 Hour**

Location	Task	Notes
Vacuum System	Change blower oil	SGL
	Change hydraulic fluid	THF

**Vacuum System**

**Change Blower Oil**

Change oil every 1000 hours. Change oil more frequently if working in dusty conditions.

- Drain at drain plug (3) while oil is warm.
- Add SGL at breather (1) until oil is at halfway point on sight glass (2).

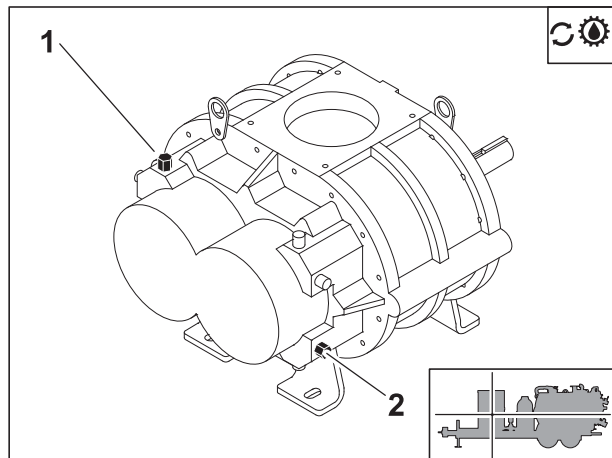

j43om033h.eps

### Change Hydraulic Fluid

Drain hydraulic fluid (2) and add (1) THF every 1000 hours. Change fluid every 500 hours if jobsite temperature exceeds 100°F (38°C) more than 50% of the time.

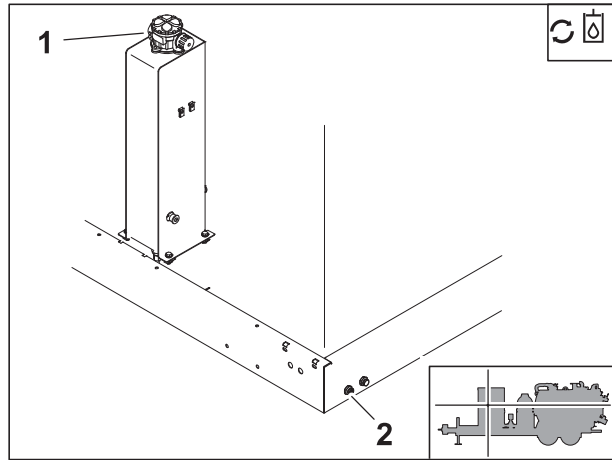

j43om034h.eps

## 2000 Hour

Location	Task	Notes
Vacuum System	Change coolant	DEAC

### Vacuum System

#### Change Coolant

Drain cooling system at drain (1) every two years or 2000 hours. Add approved coolant at expansion tank (2) to fill line.

**NOTICE:**

- The use of non-approved coolant may lead to engine damage or premature engine failure and will void engine warranty.
- See “Approved Coolant” on page 90 for list of approved coolants.

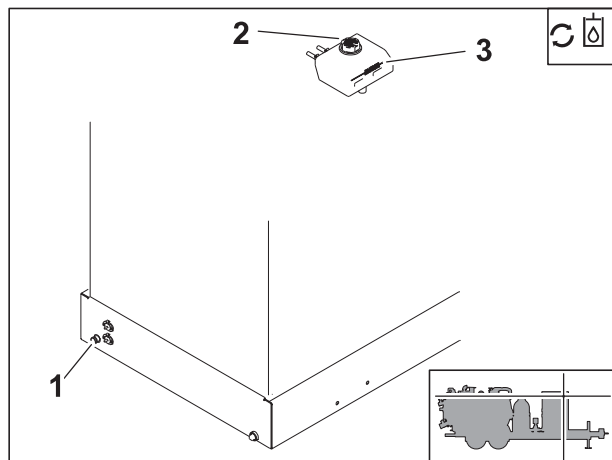

j43om035h.eps

**To fill:**

1. Slowly add coolant at expansion tank to fill line.
2. Start and operate engine for several minutes after it reaches normal operating temperature of 195°F (90°C).
3. Stop engine and allow to cool.
4. Repeat steps until coolant level is correct.

## As Needed

Location	Task	Notes
<b>Vacuum System</b>	Change air filter	
	Change water pump filter	
	Adjust blower belt tension	
	Lube blower for longterm storage	
	Change blower relief air filter	
	Replace water pump belt	
	Replace blower belt	
	Replace fan belt	
	Empty cyclonic separator canister	
	Lube reverse flow 4-way valve	MPG
	Change wireless control module batteries	3 AA
<b>Debris Tank</b>	Clean primary shutoff valve	
	Clean secondary shutoff valve	1200 Tank
<b>Trailer</b>	Check battery	
	Charge battery	



## Vacuum System

### Change Air Filter

Change air filter element when red band on filter minder (1) is visible. Push button to reset indicator.

#### To replace air filter:

1. Disengage latches (2) and remove cover (3).
2. Remove the primary (4) and secondary (5) filters from the canister (6).
3. Wipe out the canister (6) and cover (3) with a damp cloth.
4. Install the new secondary and primary filters by hand with a slight turn and firm push to seat the filters in the canister.
5. Install the cover and engage latches.
6. Reset filter minder indicator (1) by pressing the yellow button.

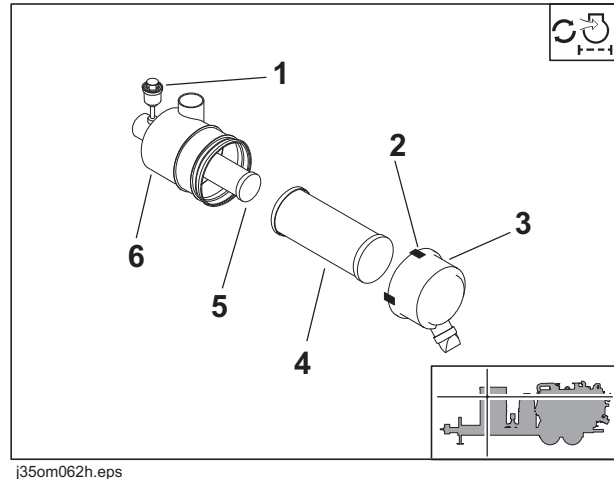

j35om062h.eps

**NOTICE:** If the cover contacts the filter before the cover is fully in place, remove cover and push filter element further into housing and try again. The cover should go on without extra force.

### Change Water Pump Filter

1. Open filter housing.
2. Remove element and rinse housing thoroughly with clean water.
3. Install new element and close filter housing.

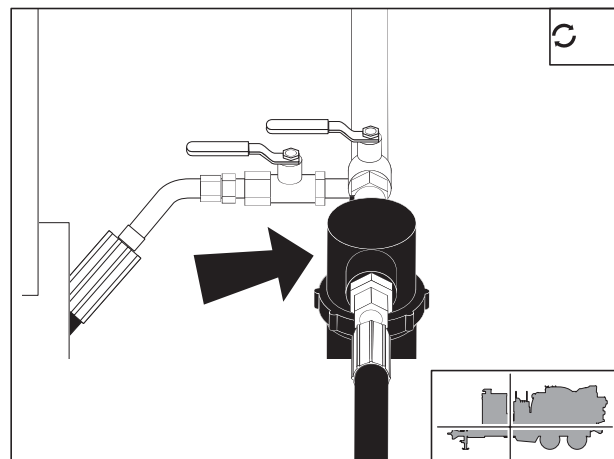

j35om040h.eps

### Adjust Blower Belt Tension

1. Turn off engine and remove key.
2. Loosen jam nut (3), pulley nut (1, alternate view 1B) and idler mount bolt (2, alternate view 2B) only enough that components can slide.
3. Rotate adjustment screw (4) using hand tools.
4. Tighten pulley nut.
5. Check belt tension at access hole (5).  
Using ultrasonic meter:
  - New belt: 97-100 Hz
  - Used belt: 90-93 HzUsing force/deflection:
  - New belt: 7 lb (31.1 N) at 1/4"
  - Used belt: 6 lb (26.7 N) at 1/4"
6. Repeat steps 2-5 until belt is properly tensioned.
7. Tighten idler mount bolt and jam nut.
8. Verify belt tension is correct.

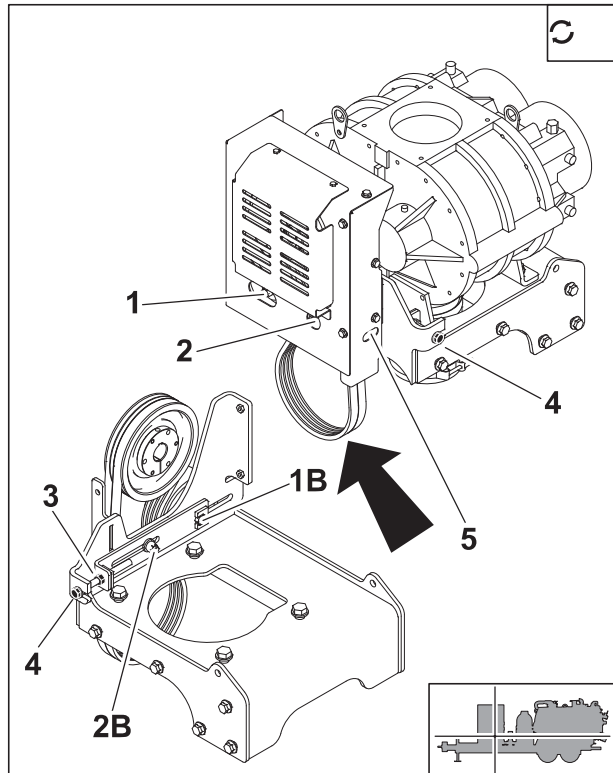

j43om043h.eps

### Lube Blower for Long-term Storage

Lubricate blower before long-term storage to help prevent rust and lockup.

1. Remove plug from fitting at filter.
2. Start engine.
3. Spray light oil into port and run unit for 1-2 minutes.
4. Turn off engine.

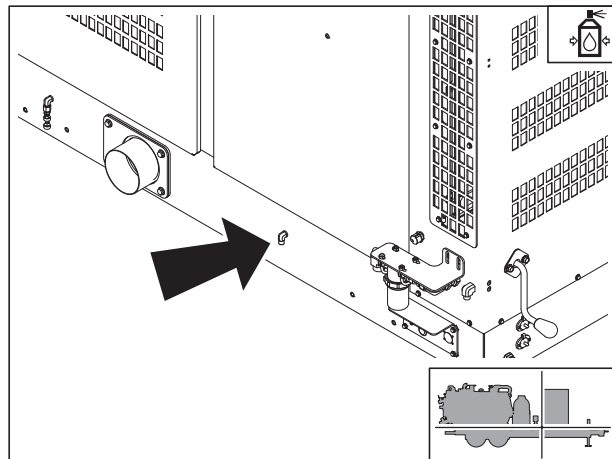

j43om038h.eps



### Change Blower Relief Air Filter

Check air filter whenever vacuum gauge goes over 16" (406 mm) of mercury. Change as needed.

**NOTICE:** Operating system above 16" (406 mm) of mercury may result in blower damage.

1. Remove clamp.
2. Remove filter and discard.
3. Install new filter.
4. Replace clamp.

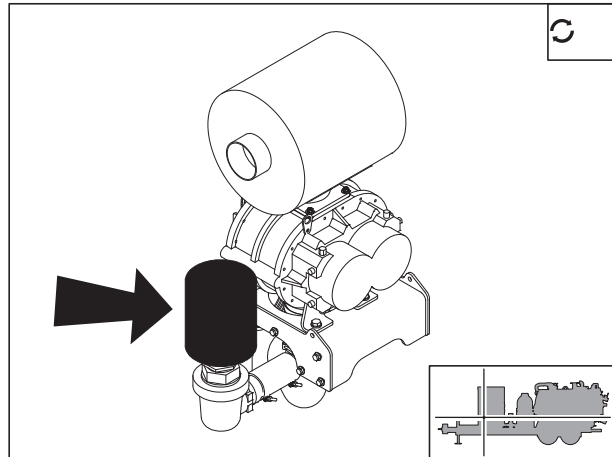

j43om039h.eps

### Empty Cyclonic Separator Canister

**IMPORTANT:** Depressurize tank before emptying cyclonic canister, cleaning filter, clearing hoses or opening any doors.

Empty cyclonic separator canister as needed. Open door and dump tank. Clean out cyclone through upper access door as needed.

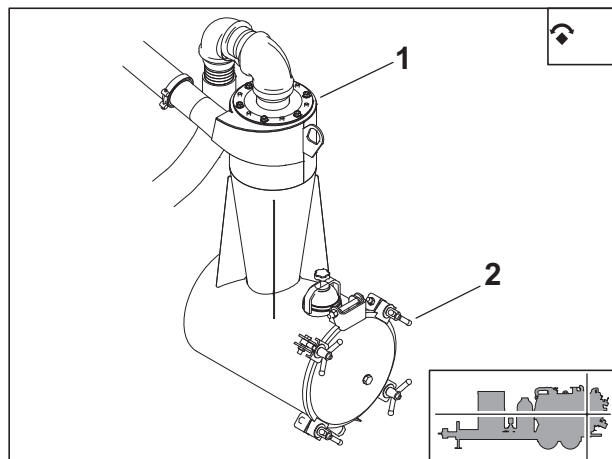

j35om069h.eps

### Replace Water Pump Belt

Replace water pump belt (3) every 2000 hours.

### Replace Blower Belt

Replace blower belt (2) every 2000 hours.

### Replace Fan Belt

Replace fan belt (1) every 2000 hours.

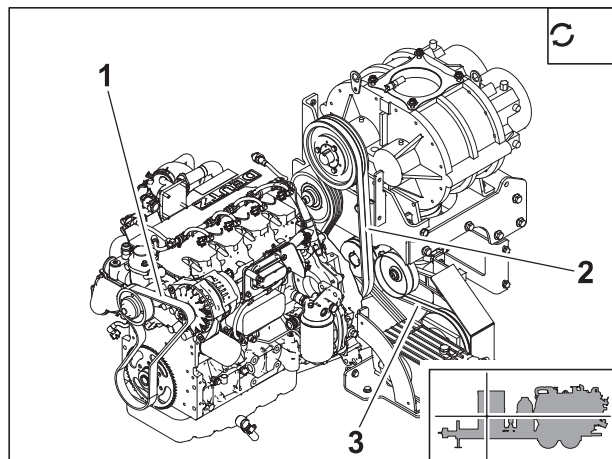

j43om037h.eps

### Lube Reverse Flow 4-Way Valve

Lube reverse flow 4-way valve at zerk (shown) with MPG as needed. Also open left access panel of power unit and lube zerk on other side of valve.

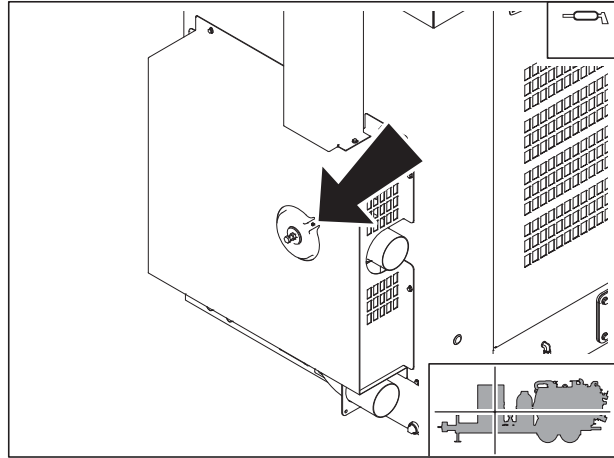

j43om046h.eps



### Change Wireless Control Module Batteries

Change batteries in wireless control module as needed. Unit requires 3 AA batteries.

#### To change:

1. Insert 3 AA batteries into the slots on the back of the battery adapter case housing as indicated on the case.
2. Slide the battery adapter into the battery compartment as shown.

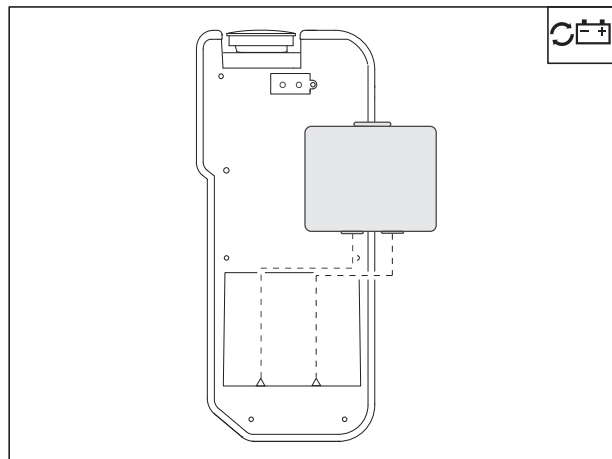

VacWirelessControlBattery.eps



## Debris Tank

### Clean Primary Shutoff Valve

Clean primary shutoff valve as needed. Replace primary shutoff valve as needed.

#### To clean:

1. Open tank door. See "Open/Close Tank Door" on page 78.
2. Spray valve housing inside vacuum tank with high-pressure water.
3. Store water pressure hose.
4. Close tank door. See "Open/Close Tank Door" on page 78.

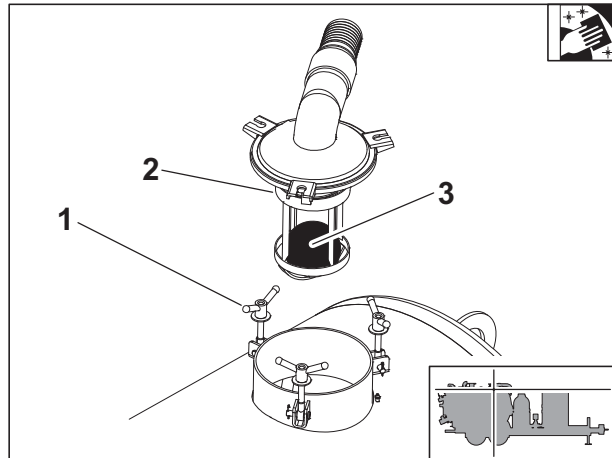

j35om027h.eps

#### To remove:

1. Loosen three wingnuts (1) and pull out valve housing (2).
2. Remove ball (3).
3. Clean ball and housing with high-pressure water.
4. Replace ball and housing.
5. Tighten wingnuts.

**Clean Secondary Shutoff Valve (1200 Tank)**

Clean secondary shutoff valve as needed.  
Replace secondary shutoff valve as needed.

**To clean:**

1. Loosen wingnuts and open water trap door.
2. Remove filter canister lid and remove filter element.
3. Drain water from element housing.
4. Spray valve housing and rubber seat inside water trap housing with high-pressure water.
5. Disconnect water pressure hose and store properly.
6. Replace water filter canister lid and close water trap door.
7. Tighten wingnuts.

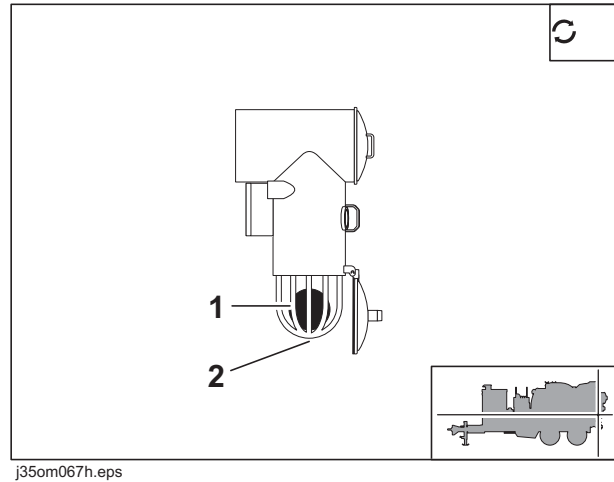

**To remove:**

1. Open hinged water trap door.
2. Remove three fasteners inside water trap to remove ball housing.
3. Clean ball and housing with high pressure water.
4. Replace ball and housing.
5. Close water trap door and tighten wingnuts.

## Trailer

### Check Battery

Check battery as needed. Keep battery clean and terminals free of corrosion.

#### To clean:

1. Turn battery disconnect switch, if equipped, to the off position.
2. Ensure that no ignition sources are near batteries.
3. Loosen and remove battery cable clamps carefully, **negative (-)** cable first.
4. Clean cable clamps and terminals to remove dull glaze.
5. Check for signs of internal corrosion in cables.
6. Apply MPG to terminals after cleaning to reduce corrosion.
7. Connect battery cable clamps, **positive (+)** cable first.
8. Tighten any loose connections.
9. Ensure that battery tiedowns are secure.
10. Turn battery disconnect switch to the on position.

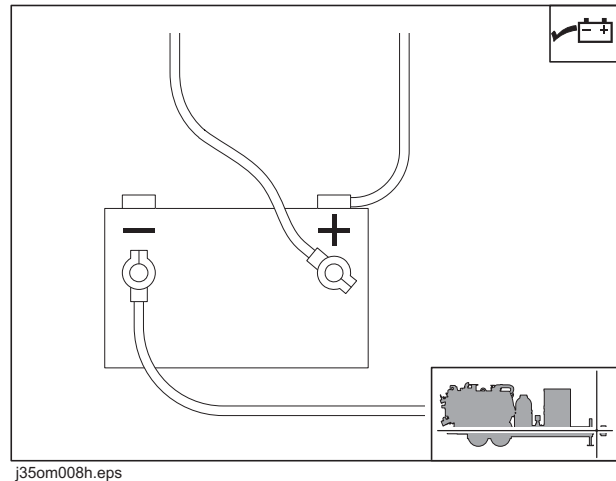
**WARNING**

Explosion possible. Serious injury or equipment damage could occur. Follow directions carefully.

**To help avoid injury:** Do not create sparks and do not short across battery terminals for any reason.

## Charge Battery



**⚠ WARNING** Explosion possible. Serious injury or equipment damage could occur. Follow directions carefully.



### To help avoid injury:

- Use a single 12V maximum source for charging. Do not connect to rapid chargers or dual batteries.
- Use caution and wear personal protective equipment such as safety eyewear, when charging or cleaning battery.
- Keep sparks, flames, and any ignition source away from batteries at all times. Internal contents are extremely hazardous. Leaking fluid is corrosive. Battery may be explosive at higher temperatures.
- NEVER lean over battery when making connections.
- Do not allow vehicles to touch when charging.
- Do not attempt to charge a battery that is leaking, bulging, heavily corroded, frozen, or otherwise damaged.
- NEVER short-circuit battery terminals for any reason or strike battery posts or cable terminals.
- Refer to MSDS for additional information regarding this battery.

### Before You Start

Electronic components can be easily damaged by electrical surges. Jump starting can damage electronics and electrical systems, and is not recommended. Try to charge the battery instead. Use quality large diameter jumper cables capable of carrying high currents (400 amps or more). Cheap cables may not allow enough current flow to charge a dead/discharged battery.

Read all steps thoroughly and review illustration before performing procedure.

**Charging Procedure (Engine Off)**

1. Park service vehicle close to disabled equipment but do not allow vehicles to touch. Engage parking brake in both vehicles.
2. Turn the ignition switch to the OFF position in both vehicles, and turn off all electrical loads. Disconnect the machine controller.

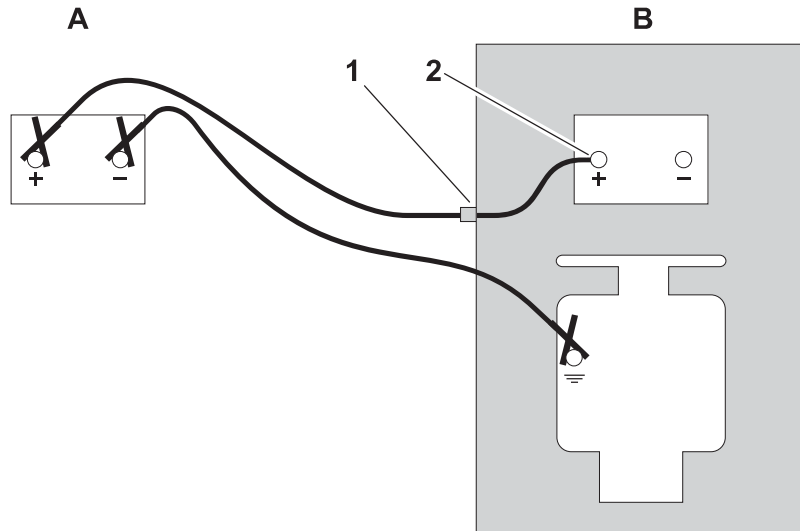

3. Inspect battery in disabled vehicle (B) for signs of cracking, bulging, leaking, or other damage. Connect red positive (+) jumper cable clamp to positive (+) post (2) of battery in disabled vehicle first.

**IMPORTANT:** Some equipment may have a positive jumper cable terminal (1) located externally. If so equipped, connect red positive (+) jumper cable clamp to terminal.

4. Connect the other red positive (+) jumper cable clamp to positive (+) post of battery (A) in the service vehicle.
5. Connect black negative (-) cable clamp to negative (-) post of battery (A) in service vehicle.
6. Connect the other black negative (-) cable clamp to the engine or frame ground on the disabled vehicle, at least 12" (305 mm) from the failed battery, as shown.
7. Operate service vehicle engine at 1500-2000 rpm for a few minutes to build an electrical charge in the failed battery.
8. Stop engine in service vehicle.
9. Remove jumper cables from the service vehicle, black negative (-) clamp first. Do not allow clamps to touch.
10. Remove black negative (-) cable clamp from the disabled engine or frame ground first.
11. Remove red positive (+) cable clamp from the disabled vehicle positive (+) battery post last.
12. Reconnect machine controller and try to start disabled vehicle.

If the disabled vehicle did not start, check for loose or corroded battery cable connections. Poor connections will prevent current from charging the failed battery. Clean terminals and posts if necessary and repeat steps above.

## 200 Mile

### Trailer

#### Adjust Electric Brakes (Initial)

Adjust brakes after 200 miles (320 km).

1. Place adequate jack stands under frame rails and remove wheels.
2. Remove cover from adjusting slot on bottom of backing plate.
3. Rotate adjuster starwheel with screwdriver or brake spoon to expand brake shoes. Adjust until drum is very difficult to turn by hand.
4. Rotate starwheel the other direction until drum turns with slight drag.
5. Replace adjusting slot cover and replace wheel.
6. Repeat procedure for all remaining brakes.
7. Remove jack stands and lower wheels to ground.

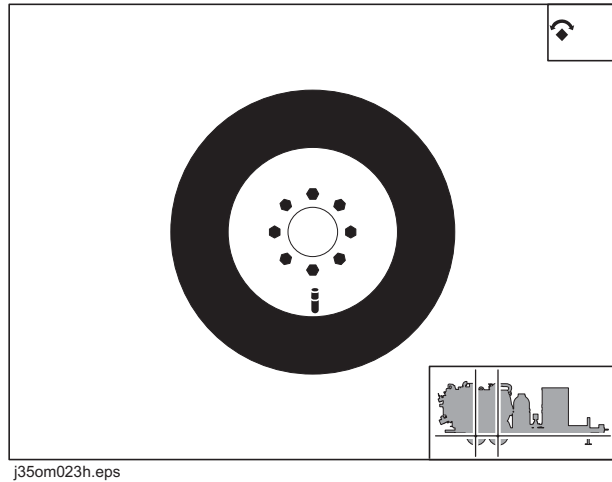

## 3000 Mile

### Trailer

#### Adjust Electric Brakes

Adjust brakes every 3000 miles (5000 km).

1. Place adequate jack stands under frame rails and remove wheels.
2. Remove cover from adjusting slot on bottom of backing plate.
3. Rotate adjuster starwheel with screwdriver or brake spoon to expand brake shoes. Adjust until drum is very difficult to turn by hand.
4. Rotate starwheel the other direction until drum turns with slight drag.
5. Replace adjusting slot cover and replace wheel.
6. Repeat procedure for all remaining brakes.
7. Remove jack stands and lower wheels to ground.

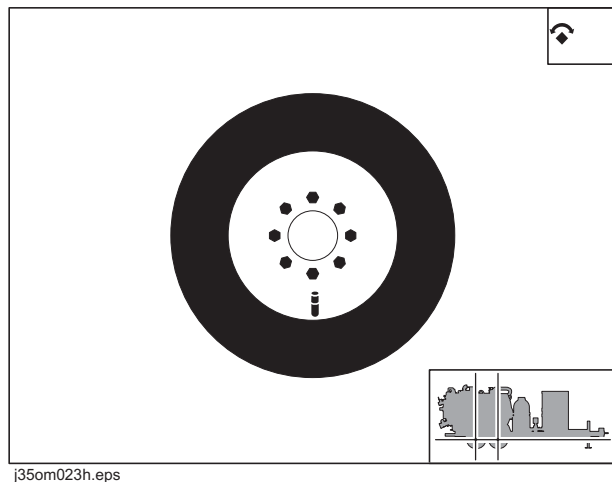

## 10,000 Mile

Location	Task	Notes
Truck	Check mounting bolts and springs	
	Check accessory mounting bolts	

### Truck

#### Check Mounting Bolts and Springs

Check mounting bolts and springs (shown, underneath and both sides) every 10,000 miles for looseness and damage. Springs (1) should be 3" (76 mm). Loosen or tighten bolt to adjust spring length. Tighten all other indicated hardware to 240 ft•lb (325 N•m).

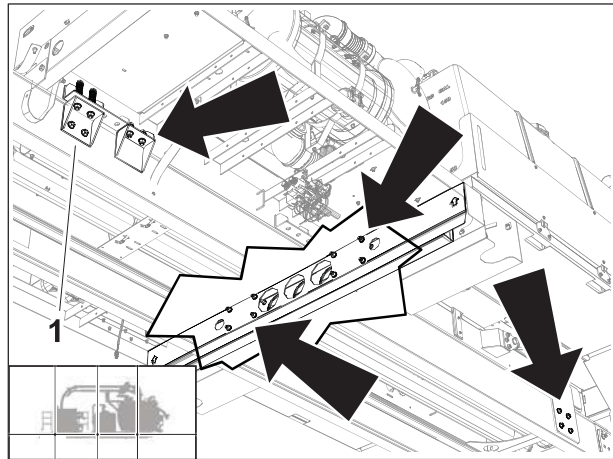

j39om013w.eps

#### Check Accessory Mounting Bolts

Check accessory (fender, hitch, water heater, bumper, skid extension, front tool rack) mounting bolts every 10,000 miles for looseness and damage. Tighten or replace as needed.

## 12,000 Mile

Location	Task	Notes
Trailer	Inspect brake shoes and linings	
	Adjust and lubricate bearings	



### Trailer

#### Inspect Brake Shoes and Linings

Inspect shoes and linings every 12 months or 12,000 miles (20 000 km) for wear. When lining is worn to 1/16" (2 mm) or less, replace linings. Replace shoe and lining if contaminated by oil.

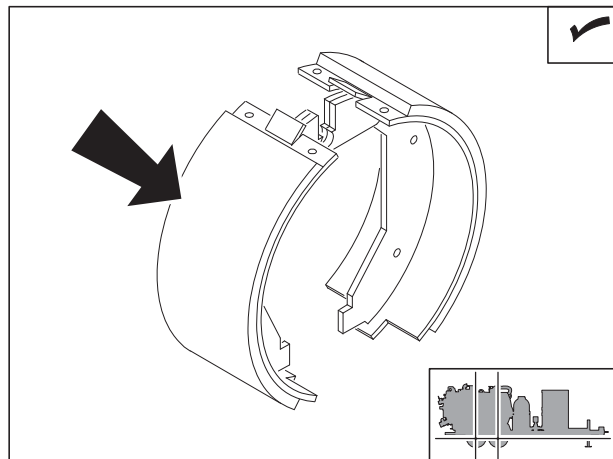

j35om025h.eps



**Adjust and Lubricate Bearings**

1. Place adequate jack stands under frame rails and remove wheels.
2. Unscrew grease cap (11) while holding the hub stationary.
3. Bend locking tang (14) down from outer spindle nut (13) and remove spindle nut (3).
4. Remove tang washer, unscrew inner spindle nut and remove spindle washer (16).
5. Remove hub from spindle. Do not drop outer bearing cone.
6. Pry seal (2) from hub and remove inner bearing cone (3).
7. Inspect brake drum for excessive wear or heavy scoring.

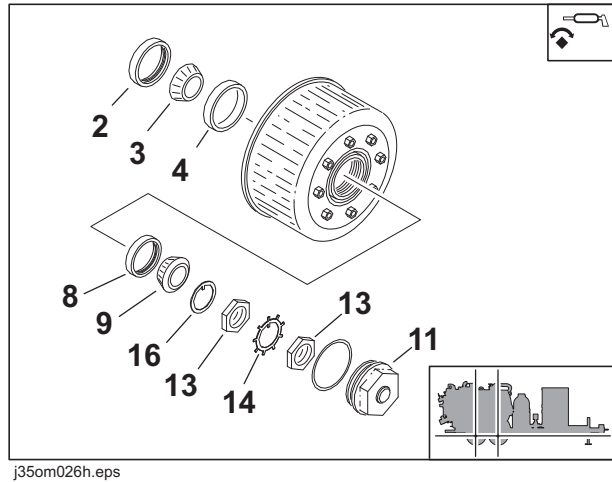

j35om026h.eps

Condition	Recommended Action
Brake drum worn more than .020" (.5 mm).	Remachine drum surface
Brake drum worn out of round more than .015" (.39 mm).	
Brake drum has scoring and other wear greater than .090" (2.29 mm)	Replace drum

8. Clean all grease from bearing cups (4,8), cones (9,3), hardware, and hub bore using suitable solvent. Dry components with lint free cloth.
9. Inspect bearing cups and cones for pitting, spalling, and corrosion. Replace if damaged.
10. Pack all cones using an extreme pressure, water resistant lithium complex grease. Apply light coating of grease to bearing cones.
11. Install the bearing and washer into the hub. Thread on the inner nut, rotate the hub, and tighten the nut until the hub will not rotate. This requires a minimum of 100 ft•lb (136 N•m) of torque.
12. Loosen the nut to remove preload torque.
13. Hand tighten the nut and back it off 1/4 to 3/4 of a turn.
14. Place tang washer on spindle and bend one tang inward over the nut. This will keep the inner nut from turning while torque is applied to the outer nut.
15. Install the outer nut and torque to 225-250 ft•lb (305-309 N•m). Ensure that inner nut does not turn. Bend two tangs from the tang washer over the outer flats to secure.
16. Install cap with o-ring and plug installed. Rotate the hub and check bearing adjustment. Allowable end play is .001-.010" (.025-.25 mm).

# Specifications

## FX60-800

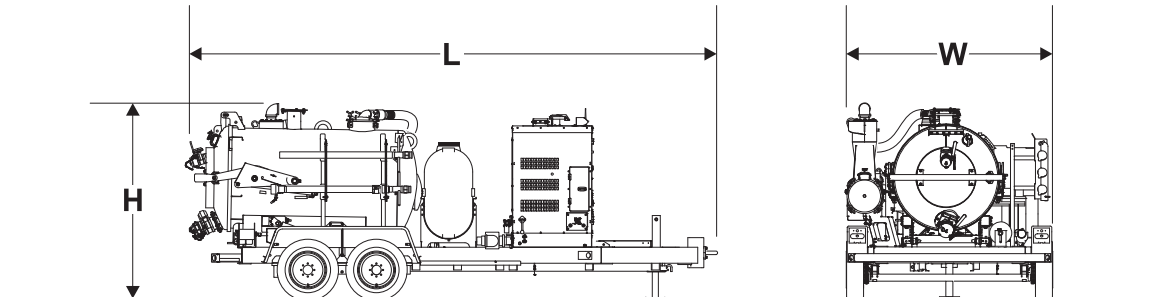

j43om040h.eps

Dimensions		U.S.	Metric
L	Length	263 in	6.7 m
H	Height	92 in	2.3 m
W	Width	97.5 in	2.5 m
	Trailer width	100.5 in	2.5 m
Dry weight *		10,700 lb	4853 kg
Weight with all tanks filled with water *		18,900 lb	8573 kg

\* Options included on weight calculation: boom, reverse flow, cyclonic filter, heater, and 200-gallon water tank on a T18S trailer.

Vac Tank	U.S.	Metric
Capacity	800 gal	3028 L
Length	98 in	2.5 m
Diameter	50 in	1.3 m
Drain valve size	6 in	152 mm
Inlet valve size	4 in	102 mm

Engine	U.S.	Metric
Deutz TD2.9L4, diesel, Tier 4, turbocharged		
Cooling medium	liquid	
Injection	direct	
Number of cylinders	4	
Displacement	178 in <sup>3</sup>	2.9 L
Bore	3.62 in	92 mm
Stroke	4.33 in	110 mm
Engine manufacturer's gross power rating (per SAE J1995)	74 hp	55 kW
Estimated net power rating (per SAE 1349)	71 hp	53 kW
Rated engine speed	2600 rpm	2600 rpm
Emissions compliance	EPA Tier 4	EU Stage IIIB

\* Exceeding these operating angles will cause engine damage. This DOES NOT IMPLY machine is stable to maximum angle of safe engine operation.

Hydraulic system	U.S.	Metric
Pressure	2500 psi	172 bar
Drive type	gear	
Tank lift cylinder size (2)	3 in	76 mm
Maximum tilt angle	45°	45°

#### Noise levels (without reverse flow)

Operator 82 dBA sound pressure per ISO 6394, at operator ear 27 ft (8 m) behind power unit.  
 Exterior 110 dBA sound power per ISO 6393.

#### Noise levels (with reverse flow)

##### Suction mode:

Operator 83 dBA sound pressure per ISO 6394, at operator ear 27 ft (8 m) behind power unit.  
 Exterior 112 dBA sound power per ISO 6393.

##### Reverse flow mode:

Operator 83 dBA sound pressure per ISO 6394, at operator ear 27 ft (8 m) behind power unit.  
 Exterior 110 dBA sound power per ISO 6393.

**Battery**

SAE res. cap. 195 min; SAE cold crank @ 0°F (-18°C) 925A, 12V

<b>Vacuum system</b>	<b>U.S.</b>	<b>Metric</b>
Drive type	belt	
Displacement	1020 cfm	28.9 m <sup>3</sup> /min
Maximum vacuum	16 in Hg	405 mm Hg
Filter type	washable polyester	
Filter area	130 ft <sup>2</sup>	12 m <sup>2</sup>
Suction hose size	4 in	102 mm

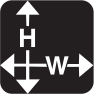

<b>Water pump system</b>	<b>U.S.</b>	<b>Metric</b>
Maximum pressure	3000 psi	207 bar
Flow	5.5 gpm	21 L/min
Hose reel capacity with water lance	50 ft	15.2 m
Antifreeze	50/50 water/antifreeze mix	
Clutch type	electric with auto de-clutch	

<b>Fluid capacities</b>	<b>U.S.</b>	<b>Metric</b>
Engine oil with filter	8.5 qt	8.0 L
Fuel tank	24 gal	91 L
Vacuum pump	1.5 qt	1.4 L
Hydraulic reservoir	6.3 gal	23.8 L
Water pump oil	41 oz	1.2 L
Water tank	200 gal	757 L

T18S Trailer		U.S.	Metric
Dimensions			
	Clearance (at jack foot pad)	12 in	305 mm
	Adj. coupler height	17-26 in	432-660 mm
	Width between fenders	80.5 in	2 m
	Width outside fenders	100.5 in	2.6 m
General			
	Number of axles	2	
	Coupler (square mount drawbar)	3 in or 2.5 in	76 mm or 64 mm
	Type of brakes	electric	
	Lug nut torque	300 ft•lb	407 N•m
	Hitch bolt torque	200 ft•lb	271 N•m
	Electrical system	12V DC	
Tire			
	215/75R-17.5, H16TL	125 psi	8.6 bar
Load rating			
	Tongue weight (empty)	2330 lb	1057 kg
	Tongue weight (full water)	2460 lb	1116 kg
	Max tongue load	2700 lb	1225 kg
	GVWR (gross vehicle weight rating)	18,000 lb	8165 kg
	GAWR (gross axle weight rating, each)	8,000 lb	3632 kg

Load ratings for speeds up to 65 mph (104 km/h).

## FX60-1200

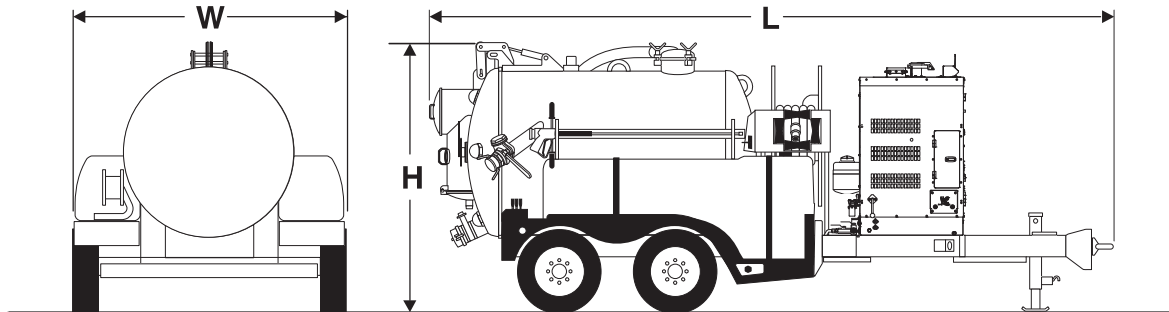

j43om041h.eps

Dimensions		U.S.	Metric
L	Length	245 in	6.2 m
H	Height	99 in	2.5 m
W	Width	100.5 in	2.55 m
Dry weight		12,060 lb	5420 kg
Weight with all tanks filled with water *		25,400 lb	11 520 kg

\* Options included on weight calculation: boom and heater on a T26S trailer.

Tank	U.S.	Metric
Capacity	1200 gal	4542 L
Length	106 in	2.7 m
Diameter	60 in	1.5 m
Drain valve size	6 in	152 mm
Inlet valve size	4 in	102 mm

Engine	U.S.	Metric
Deutz TD2.9L4, diesel, Tier 4, turbocharged		
Cooling medium	liquid	
Injection	direct	
Number of cylinders	4	
Displacement	178 in <sup>3</sup>	2.9 L
Bore	3.62 in	92 mm
Stroke	4.33 in	110 mm
Engine manufacturer's gross power rating (per SAE J1995)	74 hp	55 kW
Estimated net power rating (per SAE 1349)	71 hp	53 kW
Rated engine speed	2600 rpm	2600 rpm
Emissions compliance	EPA Tier 4	EU Stage IIIB

\* Exceeding these operating angles will cause engine damage. This DOES NOT IMPLY machine is stable to maximum angle of safe engine operation.

Hydraulic system	U.S.	Metric
Pressure	2500 psi	172 bar
Drive type	gear	
Tank lift cylinder size (1)	4 in	102 mm
Maximum tilt angle	50°	50°

#### Noise levels (without reverse flow)

Operator 82 dBA sound pressure per ISO 6394, at operator ear 27 ft (8 m) behind power unit.  
 Exterior 110 dBA sound power per ISO 6393.

#### Noise levels (with reverse flow)

##### Suction mode:

Operator 83 dBA sound pressure per ISO 6394, at operator ear 27 ft (8 m) behind power unit.  
 Exterior 112 dBA sound power per ISO 6393.

##### Reverse flow mode:

Operator 83 dBA sound pressure per ISO 6394, at operator ear 27 ft (8 m) behind power unit.  
 Exterior 110 dBA sound power per ISO 6393.

**Battery**

SAE res. cap. 195 min; SAE cold crank @ 0°F (-18°C) 925A, 12V

<b>Vacuum system</b>	<b>U.S.</b>	<b>Metric</b>
Drive type	belt	
Displacement	1020 cfm	28.9 m <sup>3</sup> /min
Maximum vacuum	16 in Hg	405 mm Hg
Filter type	washable polyester	
Filter area	130 ft <sup>2</sup>	12 m <sup>2</sup>
Suction hose size	4 in	102 mm

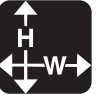

<b>Water pump system</b>	<b>U.S.</b>	<b>Metric</b>
Maximum pressure	3000 psi	207 bar
Flow	5.5 gpm	21 L/min
Hose reel capacity with water lance	100 ft	30.5 m
Antifreeze	50/50 water/antifreeze mix	
Clutch type	electric with auto de-clutch	

<b>Fluid capacities</b>	<b>U.S.</b>	<b>Metric</b>
Engine oil with filter	8.5 qt	8.0 L
Fuel tank	24 gal	91 L
Vacuum pump	1.5 qt	1.4 L
Hydraulic reservoir	6.3 gal	23.8 L
Water pump oil	41 oz	1.2 L
Water tanks (2 @ 250 gal [946L] each)	500 gal	1893 L



T26S Trailer		U.S.	Metric
Dimensions			
	Clearance (at jack foot pad)	12 in	305 mm
	Adj. coupler height	18-27 in	457-686 mm
	Width between fenders	50 in	1.3 m
	Width outside fenders	100.5 in	2.6 m
General			
	Number of axles	2	
	Coupler (square mount drawbar)	3 in or 2.5 in	76 mm or 64 mm
	Type of brakes	electric	
	Lug nut torque	190-210 ft•lb	258-285 N•m
	Hitch bolt torque	300 ft•lb	407 N•m
	Electrical system	12V DC	
Tire			
	ST235/85R16, F	95 psi	6.5 bar
Load rating			
	Tongue weight (empty)	2550 lb	1160 kg
	Tongue weight (full water)	3130 lb	1420 kg
	Max tongue load	3500 lb	1588 kg
	GVWR (gross vehicle weight rating)	26,000 lb	11 793 kg
	GAWR (gross axle weight rating, each)	12,000 lb	5443 kg

Load ratings for speeds up to 65 mph (104 km/h).

## FXT60-500

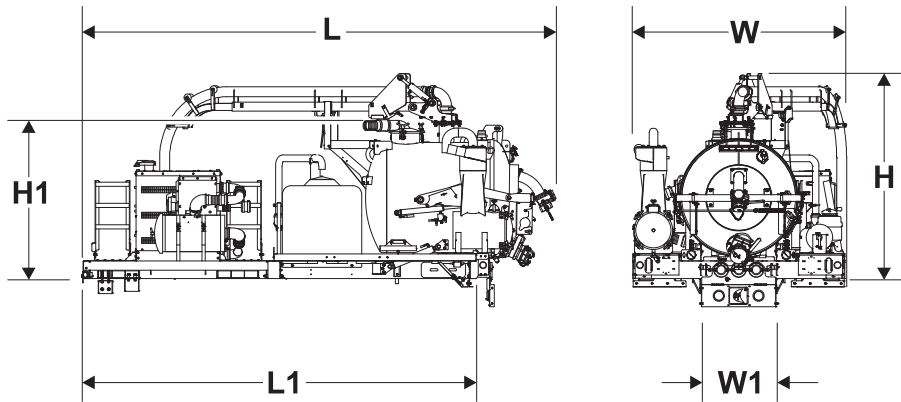

i39nm004h ens

Dimensions		U.S.	Metric
L	Overall length	214 in	5.4 m
L1	Length sitting on truck frame	178 in	4.5 m
H	Height with boom	93 in	2.4 m
H1	Height without boom	79 in	2 m
W	Overall width	96 in	2.4 m
W1	Width sitting on truck frame	34 in	864 mm
Dry weight		6175 lb	2801 kg
Weight with all tanks filled with water		12,013 lb	5449 kg

Truck Information	U.S.	Metric
Axle requirement: single		
Recommended truck GVWR	25950 lb	11771 kg

<b>Vac Tank</b>	<b>U.S.</b>	<b>Metric</b>
Capacity	500 gal	1893 L
Length	62 in	1.6 m
Diameter	50 in	1.3 m
Drain valve size	6 in	152 mm
Inlet valve size	4 in	102 mm

<b>Engine</b>	<b>U.S.</b>	<b>Metric</b>
Deutz TD2.9L4, diesel, Tier 4, turbocharged		
Cooling medium	liquid	
Injection	direct	
Number of cylinders	4	
Displacement	178 in <sup>3</sup>	2.9 L
Bore	3.62 in	92 mm
Stroke	4.33 in	110 mm
Engine manufacturer's gross power rating (per SAE J1995)	74 hp	55 kW
Estimated net power rating (per SAE 1349)	71 hp	53 kW
Rated engine speed	2600 rpm	2600 rpm
Emissions compliance	EPA Tier 4	EU Stage IIIB

\* Exceeding these operating angles will cause engine damage. This DOES NOT IMPLY machine is stable to maximum angle of safe engine operation.

<b>Hydraulic system</b>	<b>U.S.</b>	<b>Metric</b>
Pressure	2500 psi	172 bar
Drive type	engine-driven gear pump	
Tank lift cylinder size (2)	2.5 in	63.5 mm
Maximum tilt angle	45°	45°

<b>Battery</b>
SAE res. cap. 195 min; SAE cold crank @ 0°F (-18°C) 925A, 12V

<b>Vacuum system</b>	<b>U.S.</b>	<b>Metric</b>
Drive type	belt	
Displacement	1020 cfm	28.8 m <sup>3</sup> /min
Maximum vacuum	16 in Hg	406 mm Hg
Filter type	washable polyester	
Filter area	130 ft <sup>2</sup>	12 m <sup>2</sup>
Suction hose size	4 in	102 mm



<b>Water system</b>	<b>U.S.</b>	<b>Metric</b>
Maximum pressure	3000 psi	207 bar
Flow	5.5 gpm	21 L/min
Hose reel capacity (locking)	50 ft	15.2 m
Antifreeze	50/50 water/antifreeze mix	
Clutch type	electric with auto de-clutch	

<b>Fluid capacities</b>	<b>U.S.</b>	<b>Metric</b>
Engine oil with filter	8.5 qt	8.0 L
Fuel tank	24 gal	91 L
Vacuum pump	1.5 qt	1.4 L
Hydraulic reservoir	6.3 gal	23.8 L
Water pump oil	41 oz	1.2 L
Water tank	200 gal	757 L

**Noise levels (without reverse flow)**

Operator 82 dBA sound pressure per ISO 6394, at operator ear 27 ft (8 m) behind power unit.  
 Exterior 112 dBA sound power per ISO 6393.

**Noise levels (with reverse flow)**

**Suction mode:**

Operator 83 dBA sound pressure per ISO 6394, at operator ear 27 ft (8 m) behind power unit.  
 Exterior 112 dBA sound power per ISO 6393.

**Reverse flow mode:**

Operator 83 dBA sound pressure per ISO 6394, at operator ear 27 ft (8 m) behind power unit.  
 Exterior 110 dBA sound power per ISO 6393.

# FXT60-800

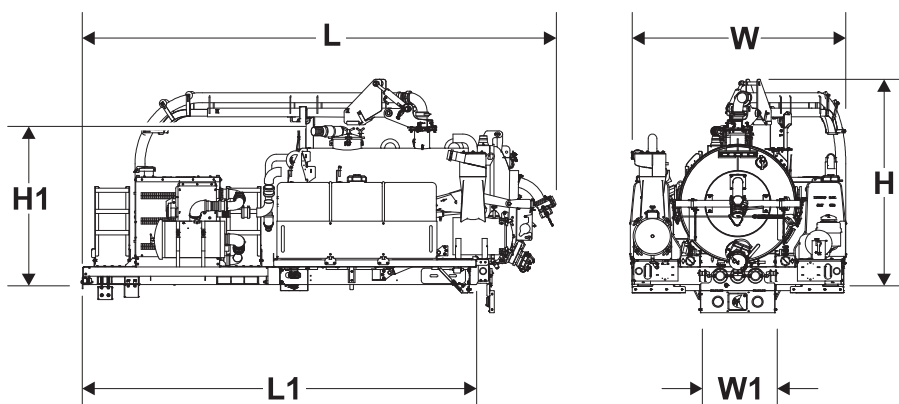

i39nm003h ens

Dimensions		U.S.	Metric
L	Overall length	214 in	5.4 m
L1	Length sitting on truck frame	178 in	4.5 m
H	Height with boom	93 in	2.4 m
H1	Height without boom	79 in	2 m
W	Overall Width	96 in	2.4 m
W1	Width sitting on truck frame	34 in	864 mm
Dry weight		6700 lb	3039 kg
Weight with all tanks filled with water		16,708 lb	7578.6 kg

Truck Information	U.S.	Metric
Axle requirement: single		
Recommended truck GVWR	33000 lb	14968.5 kg

<b>Vac Tank</b>	<b>U.S.</b>	<b>Metric</b>
Capacity	800 gal	3028 L
Length	98 in	2.5 m
Diameter	50 in	1.3 m
Drain valve size	6 in	152 mm
Inlet valve size	4 in	102 mm



<b>Engine</b>	<b>U.S.</b>	<b>Metric</b>
Deutz TD2.9L4, diesel, Tier 4, turbocharged		
Cooling medium	liquid	
Injection	direct	
Number of cylinders	4	
Displacement	178 in <sup>3</sup>	2.9 L
Bore	3.62 in	92 mm
Stroke	4.33 in	110 mm
Engine manufacturer's gross power rating (per SAE J1995)	74 hp	55 kW
Estimated net power rating (per SAE 1349)	71 hp	53 kW
Rated engine speed	2600 rpm	2600 rpm
Emissions compliance	EPA Tier 4	EU Stage IIIB

\* Exceeding these operating angles will cause engine damage. This DOES NOT IMPLY machine is stable to maximum angle of safe engine operation.

<b>Hydraulic system</b>	<b>U.S.</b>	<b>Metric</b>
Pressure	2500 psi	172 bar
Drive type	engine-driven gear pump	
Tank lift cylinder size (2)	2.5 in	63.5 mm
Maximum tilt angle	45°	45°

<b>Battery</b>
SAE res. cap. 195 min; SAE cold crank @ 0°F (-18°C) 925A, 12V

<b>Vacuum system</b>	<b>U.S.</b>	<b>Metric</b>
Drive type	belt	
2-Lobe blower displacement	1020 cfm	28.9 m <sup>3</sup> /min
Maximum vacuum	16 in Hg	405 mm Hg
Filter type	washable polyester	
Filter area	130 ft <sup>2</sup>	12 m <sup>2</sup>
Suction hose size	4 in	102 mm

<b>Water system</b>	<b>U.S.</b>	<b>Metric</b>
Maximum pressure	3000 psi	207 bar
Flow	5.5 gpm	21 L/min
Hose reel capacity (locking)	50 ft	15.2 m
Antifreeze	50/50 water/antifreeze mix	
Clutch type	electric with auto de-clutch	

<b>Fluid capacities</b>	<b>U.S.</b>	<b>Metric</b>
Engine oil with filter	8.5 qt	8.0 L
Fuel tank	24 gal	91 L
Vacuum pump	1.5 qt	1.4 L
Hydraulic reservoir	6.3 gal	23.8 L
Water pump oil	41 oz	1.2 L
Water tank	400 gal	757 L

**Noise levels (without reverse flow)**

Operator 82 dBA sound pressure per ISO 6394, at operator ear 27 ft (8 m) behind power unit.  
 Exterior 112 dBA sound power per ISO 6393.

**Noise levels (with reverse flow)**
**Suction mode:**

Operator 83 dBA sound pressure per ISO 6394, at operator ear 27 ft (8 m) behind power unit.  
 Exterior 112 dBA sound power per ISO 6393.

**Reverse flow mode:**

Operator 83 dBA sound pressure per ISO 6394, at operator ear 27 ft (8 m) behind power unit.  
 Exterior 110 dBA sound power per ISO 6393.

# Support

## Procedure

Notify your dealer immediately of any malfunction or failure of Ditch Witch® equipment.

Always give model, serial number, and approximate date of your equipment purchase. This information should be recorded and placed on file by the owner at the time of purchase.

Return damaged parts to dealer for inspection and warranty consideration if in warranty time frame.

Order genuine Ditch Witch replacement or repair parts from your authorized Ditch Witch dealer. Use of another manufacturer's parts may void warranty consideration.



## Resources

### Publications

Contact your Ditch Witch dealer for publications and videos covering safety, operation, service, and repair of your equipment.

### Ditch Witch® Training

For information about on-site, individualized training, contact your Ditch Witch dealer.



---

# Warranty

## Ditch Witch® Equipment and Replacement Parts Limited Warranty Policy

Subject to the limitation and exclusions herein, free replacement parts will be provided at any authorized Ditch Witch dealership for any Ditch Witch equipment or parts manufactured by The Charles Machine Works, Inc. (CMW) that fail due to a defect in material or workmanship within one (1) year of first commercial use. Free labor will be provided at any authorized Ditch Witch dealership for installation of parts under this warranty during the first year following "initial commercial" use of the serial-numbered Ditch Witch equipment on which it is installed. The customer is responsible for transporting their equipment to an authorized Ditch Witch dealership for all warranty work.

### Exclusions from Product Warranty

- All incidental or consequential damages.
- All defects, damages, or injuries caused by misuse, abuse, improper installation, alteration, neglect, or uses other than those for which products were intended.
- All defects, damages, or injuries caused by improper training, operation, or servicing of products in a manner inconsistent with manufacturer's recommendations.
- All engines and engine accessories (these are covered by original manufacturer's warranty).
- Tires, belts, and other parts which may be subject to another manufacturer's warranty (such warranty will be available to purchaser).
- ALL IMPLIED WARRANTIES NOT EXPRESSLY STATED HEREIN, INCLUDING ANY WARRANTY OF FITNESS FOR A PARTICULAR PURPOSE AND MERCHANTABILITY.

IF THE PRODUCTS ARE PURCHASED FOR COMMERCIAL PURPOSES, AS DEFINED BY THE UNIFORM COMMERCIAL CODE, THEN THERE ARE NO WARRANTIES WHICH EXTEND BEYOND THE FACE HEREOF AND THERE ARE NO IMPLIED WARRANTIES OF ANY KIND WHICH EXTEND TO A COMMERCIAL BUYER. ALL OTHER PROVISIONS OF THIS LIMITED WARRANTY APPLY INCLUDING THE DUTIES IMPOSED.

Ditch Witch products have been tested to deliver acceptable performance in most conditions. This does not imply they will deliver acceptable performance in all conditions. Therefore, to assure suitability, products should be operated under anticipated working conditions prior to purchase.

Defects will be determined by an inspection within thirty (30) days of the date of failure of the product or part by CMW or its authorized dealer. CMW will provide the location of its inspection facilities or its nearest authorized dealer upon inquiry. CMW reserves the right to supply remanufactured replacement parts under this warranty as it deems appropriate.

Extended warranties are available upon request from your local Ditch Witch dealer or CMW.

Some states do not allow exclusion or limitation of incidental or consequential damages, so above limitation of exclusion may not apply. Further, some states do not allow exclusion of or limitation of how long an implied warranty lasts, so the above limitation may not apply. This limited warranty gives product owner specific legal rights and the product owner may also have other rights which vary from state to state.

For information regarding this limited warranty, contact CMW's Product Support department, P.O. Box 66, Perry, OK 73077-0066, or contact your local Ditch Witch dealer.

First version: 1/91; Latest version: 11/11

**A Note To  
Ditch Witch  
Equipment Owners:**

If your equipment was purchased through a Ditch Witch dealer, there is no need to read further.

However, if you purchased from any other source, please fill out the form on the reverse side and return it to us.

This will enable you to receive updates on this equipment as well as information on new products of interest.

Thanks for using Ditch Witch equipment.

(Please Fold Along This Line And Seal At Bottom With Tape)



NO POSTAGE  
NECESSARY  
IF MAILED  
IN THE  
UNITED STATES

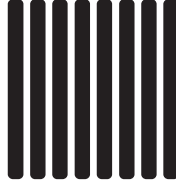

**BUSINESS REPLY MAIL**

FIRST CLASS PERMIT NO 23 PERRY OKLAHOMA

POSTAGE WILL BE PAID BY

**The Charles Machine Works, Inc.  
P.O. Box 66  
Perry, Oklahoma 73077-9989**



**A Note To  
Ditch Witch  
Equipment Owners:**

If your equipment was purchased through a Ditch Witch dealer, there is no need to read further.

However, if you purchased from any other source, please fill out the form on the reverse side and return it to us.

This will enable you to receive updates on this equipment as well as information on new products of interest.

Thanks for using Ditch Witch equipment.

(Please Fold Along This Line And Seal At Bottom With Tape)



NO POSTAGE  
NECESSARY  
IF MAILED  
IN THE  
UNITED STATES

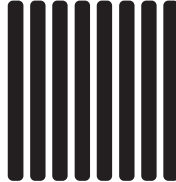

**BUSINESS REPLY MAIL**

FIRST CLASS PERMIT NO 23 PERRY OKLAHOMA

POSTAGE WILL BE PAID BY

**The Charles Machine Works, Inc.  
P.O. Box 66  
Perry, Oklahoma 73077-9989**



# Ditch Witch® Registration Card

Please Type or Print All Information

---

Purchaser's Company Name

---

Attention

---

Street Address or P.O. Box

---

City County

---

State Zip Nation

---

( )

---

Phone Number With Area Code

---

Model Serial Number

---

Attachments/Accessories Serial Numbers

---

Attachments/Accessories Serial Numbers

---

Attachments/Accessories Serial Numbers

---

Name of Ditch Witch Dealership

---

Your Signature

# Ditch Witch® Registration Card

Please Type or Print All Information

---

Purchaser's Company Name

---

Attention

---

Street Address or P.O. Box

---

City County

---

State Zip Nation

---

( )

---

Phone Number With Area Code

---

Model Serial Number

---

Attachments/Accessories Serial Numbers

---

Attachments/Accessories Serial Numbers

---

Attachments/Accessories Serial Numbers

---

Name of Ditch Witch Dealership

---

Your Signature





# **Appendix**

## **Chapter Contents**

**Tire Safety Information**

# TIRE SAFETY INFORMATION

## 1.1. STEPS FOR DETERMINING CORRECT LOAD LIMIT – TRAILER

Determining the load limits of a trailer includes more than understanding the load limits of the tires alone. On all trailers there is a Federal certification/VIN label that is located on the forward half of the left (road) side of the unit. This certification/VIN label will indicate the trailer's Gross Vehicle Weight Rating (GVWR). This is the most the fully loaded trailer can weigh. It will also provide the Gross Axle Weight Rating (GAWR). This is the most a particular axle can weigh. If there are multiple axles, the GAWR of each axle will be provided.

If your trailer has a GVWR of 10,000 pounds or less, there is a vehicle placard located in the same location as the certification label described above. This placard provides tire and loading information. In addition, this placard will show a statement regarding maximum cargo capacity. Cargo can be added to the trailer, up to the maximum weight specified on the placard. The combined weight of the cargo is provided as a single number. In any case, remember: the total weight of a fully loaded trailer can not exceed the stated GVWR.

When loading your cargo, be sure it is distributed evenly to prevent overloading front to back and side to side. Heavy items should be placed low and as close to the axle positions as reasonable. Too many items on one side may overload a tire. The best way to know the actual weight of the trailer is to weigh it at a public scale. Talk to your dealer to discuss the weighing methods needed to capture the various weights related to the trailer. This would include the weight empty or unloaded, weights per axle, wheel, hitch or king-pin, and total weight.

Excessive loads and/or underinflation cause tire overloading and, as a result, abnormal tire flexing occurs. This situation can generate an excessive amount of heat within the tire. Excessive heat may lead to tire failure. It is the air pressure that enables a tire to support the load, so proper inflation is critical. The proper air pressure may be found on the certification/VIN label and/or on the Tire Placard. This value should never exceed the maximum cold inflation pressure stamped on the tire.

### 1.1.1. TRAILERS 10,000 POUNDS GVWR OR LESS

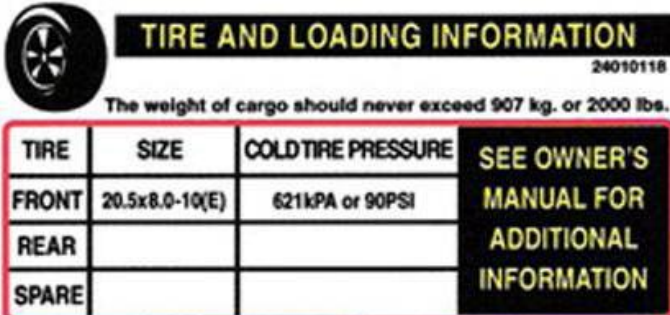

The placard features a tire icon on the left, a title bar with 'TIRE AND LOADING INFORMATION' and '24010118', and a warning statement: 'The weight of cargo should never exceed 907 kg. or 2000 lbs.'. Below this is a table with columns for 'TIRE', 'SIZE', and 'COLD TIRE PRESSURE'. The 'FRONT' row is filled with '20.5x8.0-10(E)' and '621kPA or 90PSI'. The 'REAR' and 'SPARE' rows are empty. To the right of the table is a box with the text 'SEE OWNER'S MANUAL FOR ADDITIONAL INFORMATION'.

TIRE	SIZE	COLD TIRE PRESSURE	SEE OWNER'S MANUAL FOR ADDITIONAL INFORMATION
FRONT	20.5x8.0-10(E)	621kPA or 90PSI	
REAR			
SPARE			

Tire and Loading Information Placard – Figure 1-1

1. Locate the statement, "The weight of cargo should never exceed XXX kg or XXX lbs.," on your trailer's placard. See figure 1-1.
2. This figure equals the available amount of cargo load capacity.
3. Determine the combined weight of cargo being loaded on the trailer. That weight may not safely exceed the available cargo load capacity.

The Tire Information Placard is attached adjacent to or near the trailer's VIN (Certification) label at the left front of the trailer.

**1.1.2. TRAILERS OVER 10,000 POUNDS GVWR** (NOTE: These trailers are not required to have a tire information placard on the trailer.)

1. Determine the empty weight of your trailer by weighing the trailer using a public scale or other means. This step does not have to be repeated.
2. Locate the GVWR (Gross Vehicle Weight Rating) of the trailer on your trailer's VIN (Certification) label.
3. Subtract the empty weight of your trailer from the GVWR stated on the VIN label. That weight is the maximum available cargo capacity of the trailer and must not be exceeded.

## **1.2. STEPS FOR DETERMINING CORRECT LOAD LIMIT – TOW VEHICLE**

1. Locate the statement, "The combined weight of occupants and cargo should never exceed XXX lbs.," on your vehicle's placard.
2. Determine the combined weight of the driver and passengers who will be riding in your vehicle.
3. Subtract the combined weight of the driver and passengers from XXX kilograms or XXX pounds.
4. The resulting figure equals the available amount of cargo capacity. For example, if the "XXX" amount equals 1400 lbs. and there will be five 150 lb. passengers in your vehicle, the amount of available cargo and luggage capacity is 650 lbs. (1400-750 (5 x 150) = 650 lbs.).
5. Determine the combined weight of cargo being loaded on the vehicle. That weight must not exceed the available cargo capacity calculated in Step # 4.
6. If your vehicle will be towing a trailer, load from your trailer will be transferred to your vehicle. Consult the tow vehicle's manual to determine how this weight transfer reduces the available cargo and luggage capacity of your vehicle.

## **1.3. GLOSSARY OF TIRE TERMINOLOGY**

**Bead** - the part of the tire that is made of steel wires, wrapped or reinforced by ply cords and that is shaped to fit the rim.

**Bead separation** - the breakdown of the bond between components in the bead.

**Bias ply tire** - a pneumatic tire in which the ply cords that extend to the beads are laid at alternate angles substantially less than 90 degrees to the centerline of the tread.

**Carcass** - the tire structure, except tread and sidewall rubber which, when inflated, bears the load.

**Chunking** - the breaking away of pieces of the tread or sidewall.

**Cold inflation pressure** - the pressure in the tire before you drive.

**Cord** - the strands forming the plies in the tire.

**Cord separation** - the parting of cords from adjacent rubber compounds.

**Cracking** - any parting within the tread, sidewall, or inner liner of the tire extending to cord material.

**Curb weight** - the weight of a vehicle with standard equipment.

**Groove** - the space between two adjacent tread ribs.

**Gross Axle Weight Rating (GAWR)** - the maximum weight that any axle can support, as published on the Certification / VIN label on the front left side of the trailer. Actual weight determined by weighing each axle on a public scale, with the trailer attached to the towing vehicle.

**Gross Vehicle Weight Rating (GVWR)** - the maximum weight of the fully loaded trailer, as published on the Certification / VIN label. Actual weight determined by weighing trailer on a public scale, without being attached to the towing vehicle.

**Tongue Weight** - the downward force exerted on the hitch ball or lunette by the trailer coupler.

**Innerliner** - the layer(s) forming the inside surface of a tubeless tire that contains the inflating medium within the tire.



**Innerliner separation** - the parting of the innerliner from cord material in the carcass.

**Light truck (LT) tire** - a tire designated by its manufacturer as primarily intended for use on lightweight trucks or multipurpose passenger vehicles.

**Load rating** - the maximum load that a tire is rated to carry for a given inflation pressure.

**Maximum load rating** - the load rating for a tire at the maximum permissible inflation pressure for that tire.

**Maximum permissible inflation pressure** - the maximum cold inflation pressure to which a tire may be inflated.

**Maximum loaded vehicle weight** - the sum of curb weight, accessory weight, vehicle capacity weight, and production options weight.

**Outer diameter** - the overall diameter of an inflated new tire.

**Overall width** - the linear distance between the exteriors of the sidewalls of an inflated tire, including elevations due to labeling, decorations, or protective bands or ribs.

**Ply** - a layer of rubber-coated parallel cords.

**Ply separation** - a parting of rubber compound between adjacent plies.

**Pneumatic tire** - a mechanical device made of rubber, chemicals, fabric and steel or other materials, that, when mounted on an automotive wheel, provides the traction and contains the gas or fluid that sustains the load.

**Radial ply tire** - a pneumatic tire in which the ply cords that extend to the beads are laid at substantially 90 degrees to the centerline of the tread.

**Recommended inflation pressure** - the inflation pressure provided by the vehicle manufacturer on the Tire Information label and on the Certification / VIN tag.

**Rim** - a metal support for a tire or a tire and tube assembly upon which the tire beads are seated.

**Rim diameter** - the nominal diameter of the bead seat.

**Rim size designation** - the rim diameter and width.

**Rim type designation** - the industry of manufacturer's designation for a rim by style or code.

**Rim width** - the nominal distance between rim flanges.

**Sidewall** - that portion of a tire between the tread and bead.

**Sidewall separation** - the parting of the rubber compound from the cord material in the sidewall.

**Special Trailer (ST) tire** - the "ST" is an indication the tire is for trailer use only.

**Tread** - that portion of a tire that comes into contact with the road.

**Tread rib** - a tread section running circumferentially around a tire.

**Tread separation** - pulling away of the tread from the tire carcass.

**Treadwear indicators (TWI)** - the projections within the principal grooves designed to give a visual indication of the degrees of wear of the tread.

**Vehicle maximum load on the tire** - the load on an individual tire that is determined by distributing to each axle its share of the maximum loaded vehicle weight and dividing by two.

**Vehicle normal load on the tire** - the load on an individual tire that is determined by distributing to each axle its share of the curb weight and dividing by 2.

#### **1.4. TIRE SAFETY - EVERYTHING RIDES ON IT**

The National Traffic Safety Administration (NHTSA) has published a brochure (DOT HS 809 361) that discusses all aspects of Tire Safety, as required by CFR 575.6. This brochure is reproduced in part below. It can be obtained and downloaded from NHTSA, free of charge, from the following web site: [http://www.nhtsa.dot.gov/cars/rules/TireSafety/ridesonit/tires\\_index.html](http://www.nhtsa.dot.gov/cars/rules/TireSafety/ridesonit/tires_index.html)

Studies of tire safety show that maintaining proper tire pressure, observing tire and trailer load limits (not carrying more weight in your trailer than your tires or trailer can safely handle), avoiding road hazards, and inspecting tires for cuts, slashes, and other irregularities are the most important things you can do to avoid tire failure, such as tread separation or blowout and flat tires. These actions, along with other care and maintenance activities, can also:

- ◇ Improve vehicle handling
- ◇ Help protect you and others from avoidable breakdowns and accidents
- ◇ Improve fuel economy
- ◇ Increase the life of your tires.

This booklet presents a comprehensive overview of tire safety, including information on the following topics:

- ◇ Basic tire maintenance
- ◇ Uniform Tire Quality Grading System
- ◇ Fundamental characteristics of tires
- ◇ Tire safety tips.

Use this information to make tire safety a regular part of your trailer maintenance routine. Recognize that the time you spend is minimal compared with the inconvenience and safety consequences of a flat tire or other tire failure.

#### **1.5. SAFETY FIRST—BASIC TIRE MAINTENANCE**

Properly maintained tires improve the steering, stopping, traction, and load-carrying capability of your trailer. Underinflated tires and overloaded vehicles are a major cause of tire failure. Therefore, as mentioned above, to avoid flat tires and other types of tire failure, you should maintain proper tire pressure, observe tire and trailer load limits, avoid road hazards, and regularly inspect your tires.

##### ***1.5.1. FINDING YOUR TRAILER'S RECOMMENDED TIRE PRESSURE AND LOAD LIMITS***

Tire information placards and vehicle certification labels contain information on tires and load limits. These labels indicate the vehicle manufacturer's information including:

- ◇ Recommended tire size
- ◇ Recommended tire inflation pressure
- ◇ Vehicle capacity weight
- ◇ Front and rear gross axle weight ratings

Both placards and certification labels are permanently attached to the trailer near the left front.

### **1.5.2. UNDERSTANDING TIRE PRESSURE AND LOAD LIMITS**

Tire inflation pressure is the level of air in the tire that provides it with load-carrying capacity and affects the overall performance of the trailer. The tire inflation pressure is a number that indicates the amount of air pressure—measured in pounds per square inch (psi) or kilopascals (kpa)—a tire requires to be properly inflated.

This number based on the trailer's design load limit, that is, the greatest amount of weight a trailer can safely carry and the tire size. The proper tire pressure for your trailer is referred to as the "recommended cold inflation pressure." (As you will read below, it is difficult to obtain the recommended tire pressure if your tires are not cold.)

Because tires are designed to be used on more than one type of vehicle, tire manufacturers list the "maximum permissible inflation pressure" on the tire sidewall. This number is the greatest amount of air pressure that should ever be put in the tire under normal driving conditions.

### **1.5.3. CHECKING TIRE PRESSURE**

It is important to check your trailer's tire pressure at least once a month for the following reasons:

- ◇ Most tires may naturally lose air over time.
- ◇ Tires can lose air suddenly if you drive over a pothole or other object or if you strike the curb when parking.
- ◇ With radial tires, it is usually not possible to determine underinflation by visual inspection.

For convenience, purchase a tire pressure gauge to keep with your trailer. Gauges can be purchased at tire dealerships, auto supply stores, and other retail outlets.

The recommended tire inflation pressure that manufacturers provide reflects the proper psi when a tire is cold. The term cold does not relate to the outside temperature. Rather, a cold tire is one that has not been driven on for at least three hours. When you drive, your tires get warmer, causing the air pressure within them to increase. Therefore, to get an accurate tire pressure reading, you must measure tire pressure when the tires are cold or compensate for the extra pressure in warm tires.

### **1.5.4. STEPS FOR MAINTAINING PROPER TIRE PRESSURE**

Step 1: Locate the recommended tire pressure on the trailer's tire information placard, certification label, or in the owner's manual.

Step 2: Record the tire pressure of all tires.

Step 3: If the tire pressure is too high in any of the tires, slowly release air by gently pressing on the tire valve stem with the edge of your tire gauge until you get to the correct pressure.

Step 4: If the tire pressure is too low, note the difference between the measured tire pressure and the correct tire pressure. These "missing" pounds of pressure are what you will need to add.

Step 5: Add the missing pounds of air pressure to each tire that is underinflated.

Step 6: Check all the tires to make sure they have the same air pressure (except in cases in which the front and rear tires are supposed to have different amounts of pressure).

If you have been towing your trailer and think that a tire is underinflated, fill it to the recommended cold inflation pressure indicated on your trailer's tire information placard or certification label. While your tire may still be slightly underinflated due to the extra pounds of pressure in the warm tire, it is safer to drive with air pressure that is slightly lower than the recommended cold inflation pressure than to drive with a significantly underinflated tire. Since this is a temporary fix, don't forget to recheck and adjust the tire's pressure when you can obtain a cold reading.

### **1.5.5. TIRE SIZE**

To maintain tire safety, purchase new tires that are the same size as the trailer's original tires or another size recommended by the manufacturer. Look at the tire information placard, the owner's manual, or the sidewall of the tire you are replacing to find this information. If you have any doubt about the correct size to choose, consult with your dealer.

### **1.5.6. TIRE TREAD**

The tire tread provides the gripping action and traction that prevent your trailer from slipping or sliding, especially when the road is wet or icy. In general, tires are not safe and should be replaced when the tread is worn down to 1/16 of an inch. Tires have built-in treadwear indicators that let you know when it is time to replace your tires. These indicators are raised sections spaced intermittently in the bottom of the tread grooves. When they appear "even" with the outside of the tread, it is time to replace your tires. Another method for checking tread depth is to place a penny in the tread with Lincoln's head upside down and facing you. If you can see the top of Lincoln's head, you are ready for new tires.

### **1.5.7. TIRE BALANCE AND WHEEL ALIGNMENT**

To avoid vibration or shaking of the trailer when a tire rotates, the tire must be properly balanced. This balance is achieved by positioning weights on the wheel to counterbalance heavy spots on the wheel-and-tire assembly. A wheel alignment adjusts the angles of the wheels so that they are positioned correctly relative to the trailer's frame. This adjustment maximizes the life of your tires. These adjustments require special equipment and should be performed by a qualified technician.

### **1.5.8. TIRE REPAIR**

The proper repair of a punctured tire requires a plug for the hole and a patch for the area inside the tire that surrounds the puncture hole. Punctures through the tread can be repaired if they are not too large, but punctures to the sidewall should not be repaired. Tires must be removed from the rim to be properly inspected before being plugged and patched.

### **1.5.9. TIRE FUNDAMENTALS**

Federal law requires tire manufacturers to place standardized information on the sidewall of all tires. This information identifies and describes the fundamental characteristics of the tire and also provides a tire identification number for safety standard certification and in case of a recall.

#### **1.5.9.1. UTQGS Information**

**Treadwear Number** - indicates the tire's wear rate. The higher the treadwear number is, the longer it should take for the tread to wear down. For example, a tire graded 400 should last twice as long as a tire graded 200.

**Traction Letter** - indicates a tire's ability to stop on wet pavement. A higher graded tire should allow you to stop your car on wet roads in a shorter distance than a tire with a lower grade. Traction is graded from highest to lowest as "AA", "A", "B", and "C".

**Temperature Letter** - indicates a tire's resistance to heat. The temperature grade is for a tire that is inflated properly and not overloaded. Excessive speed, underinflation or excessive loading, either separately or in combination, can cause heat build-up and possible tire failure. From highest to lowest, a tire's resistance to heat is graded as "A", "B", or "C".

### 1.5.9.2. Information on Light Truck Tires

Please refer to the diagram below.

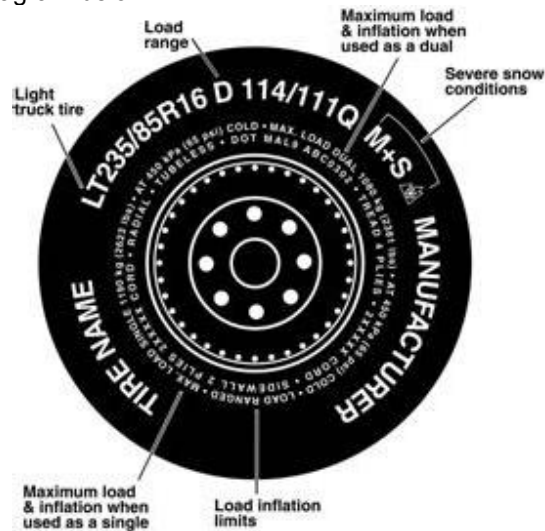

Tires for light trucks have other markings besides those found on the sidewalls of passenger tires.

**LT** - indicates the tire is for light trucks or trailers.

**ST** - indicates the tire is for trailer use only.

**Max. Load Dual kg (lbs) at kPa (psi) Cold** - indicates the maximum load and tire pressure when the tire is used as a dual, that is, when four tires are put on each axle.

**Max. Load Single kg (lbs) at kPa (psi) Cold** - indicates the maximum load and tire pressure when the tire is used as a single.

**Load Range** - identifies the tire's load-carrying capabilities and its inflation limits.

### 1.6. TIRE SAFETY TIPS

#### Preventing Tire Damage

- ◇ Slow down if you have to go over a pothole or other object in the road.
- ◇ Do not run over curbs or other foreign objects in the roadway, and try not to strike the curb when parking.

#### Tire Safety Checklist

- ◇ Check tire pressure regularly (at least once a month), including the spare (if equipped).
- ◇ Inspect tires for uneven wear patterns on the tread, cracks, foreign objects, or other signs of wear or trauma.
- ◇ Remove bits of glass and foreign objects wedged in the tread.
- ◇ Make sure your tire valves have valve caps.
- ◇ Check tire pressure before going on a long trip.
- ◇ Do not overload your trailer. Check the Tire Information and Loading Placard or Owner's Manual for the maximum recommended load for the trailer.